

This manual contains instructions for communication functions of the PCB1.

Serial communication and Console communication cannot be used together.
 When performing Serial communication, remove the Tool cable (CMD-001) from the USB port of the PC and tool cable connector of the PCB1.
 When performing Console communication, it is not required to remove the Serial communication cables.
 However, do not send a command from the master side.

1. System Configuration

1.1 When Using USB Communication Cable CMC-001-1 (sold separately)

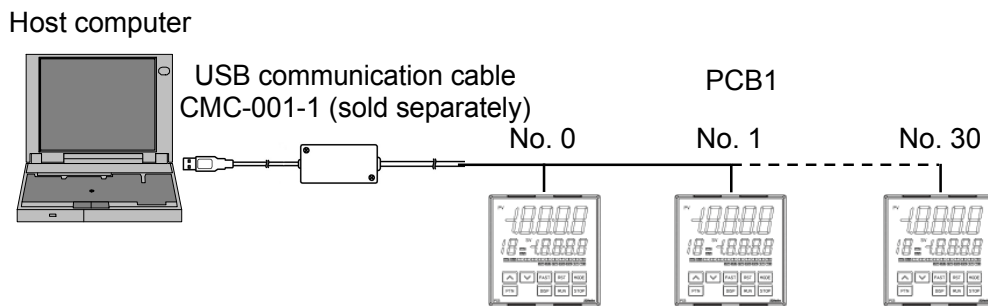

(Fig. 1.1-1)

1.2 When Using Communication Converter IF-400 (sold separately)

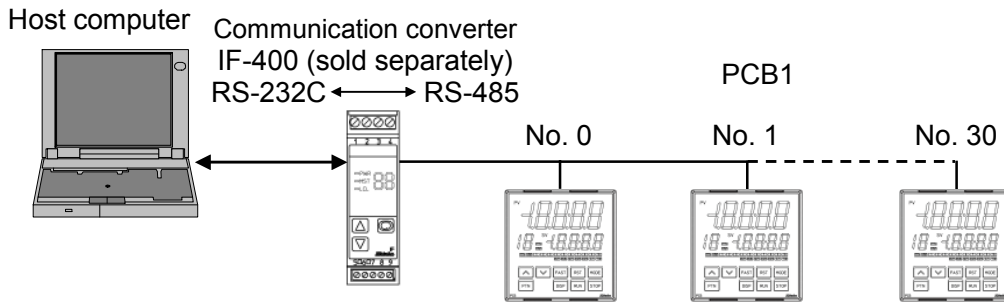

(Fig. 1.2-1)

2. Wiring

2.1 When Using USB Communication Cable CMC-001-1 (sold separately)

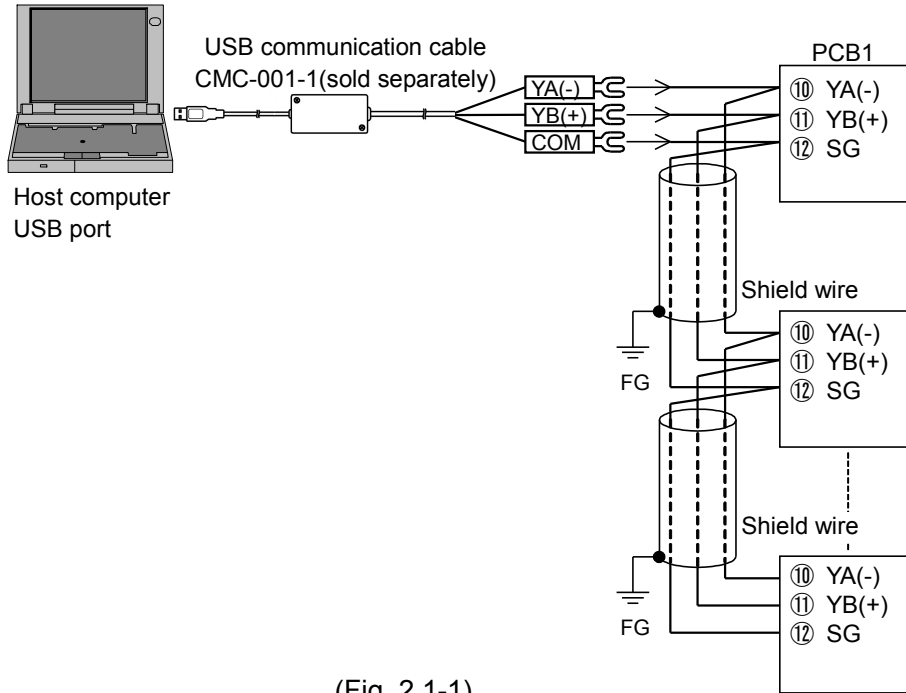

(Fig. 2.1-1)

2.2 When Using Communication Converter IF-400 (sold separately)

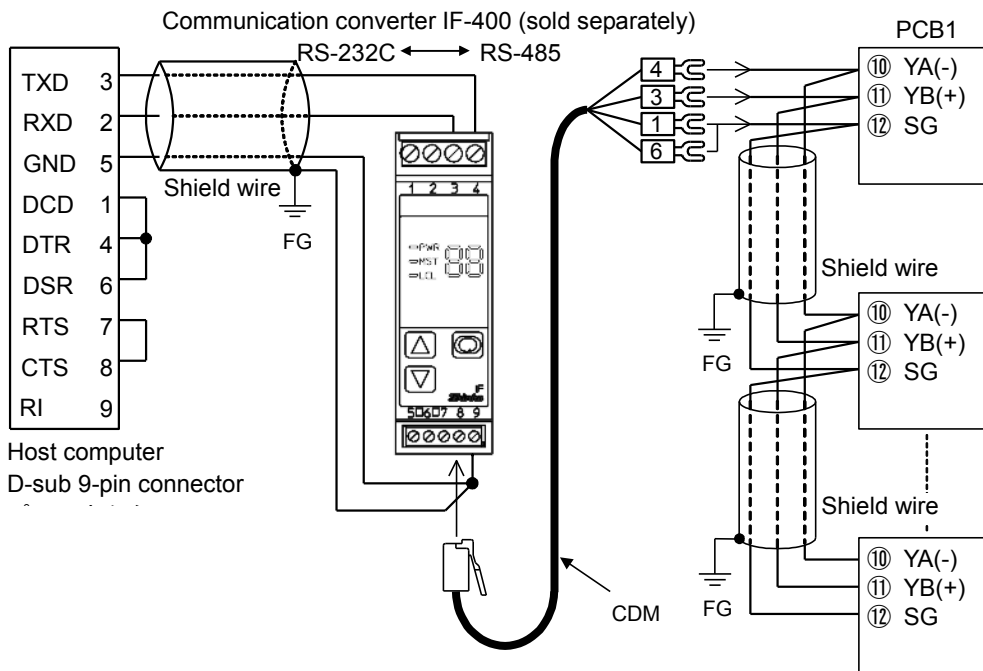

(Fig. 2.2-1)

Shield wire

Connect only one end of the shield to the FG terminal to avoid a ground loop. If both ends of the shield wire are connected to the FG terminal, the circuit will be closed, resulting in a ground loop. This may cause noise.

Be sure to ground the FG terminal.

Recommended cable: OTSC-VB 2PX0.5SQ (made by Onamba Co., Ltd.) or equivalent (Use a twisted pair cable.)

Terminator (Terminal resistor)

Communication converter IF-400 (sold separately) has a built-in terminator.

The terminator is mounted at the end of the wire when connecting multiple peripheral devices to a personal computer. The terminator prevents signal reflection and disturbance.

Do not connect a terminator to the communication line because the PCB1 has built-in pull-up and pull-down resistors.

3. Setting Communication Parameters

Set communication parameters in Engineering mode 1.

To enter Engineering setting mode 1, press and hold the **∇** and **MODE** keys (in that order) together for approx. 3 seconds in RUN mode.

Use the **▲** or **∇** key for settings (or making a selection).

To register the set data, use the **MODE** key.

Set each communication parameter following the procedure below.

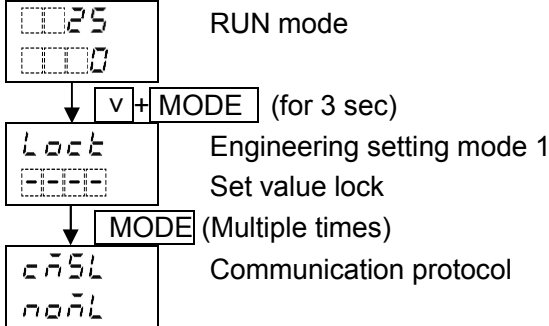

Characters, Factory Default	Setting Item, Function, Setting Range	
cā5L noāL	Communication protocol	
	• Selects communication protocol.	
	• Selection item:	
	noāL	Shinko protocol
	5ā7□	SV digital transmission (Shinko protocol)
	5ā7r	SV digital reception (Shinko protocol)
āodā āodr	Modbus ASCII mode	
	Modbus RTU mode	
cāno 000	Instrument number	
	• Sets the instrument number.	
	The instrument numbers should be set one by one when multiple instruments are connected in Serial communication, otherwise communication is impossible.	
	• Setting range: 0 to 95	
cā5P 0096	Communication speed	
	• Selects a communication speed equal to that of the host computer.	
	• Selection item:	
	0096	9600 bps
0192	19200 bps	
0384	38400 bps	
cāF7 7Eān	Data bit/Parity	
	• Selects data bit and parity.	
	• Selection item:	
	8noā	8 bits/No parity
	7noā	7 bits/No parity
	8Eān	8 bits/Even
	7Eān	7 bits/Even
8odd	8 bits/Odd	
7odd	7 bits/Odd	

Characters, Factory Default	Setting Item, Function, Setting Range				
c75f 001	Stop bit <ul style="list-style-type: none"> • Selects the stop bit. • Selection item: <table border="1"> <tr> <td>001</td> <td>1 bit</td> </tr> <tr> <td>002</td> <td>2 bits</td> </tr> </table>	001	1 bit	002	2 bits
001	1 bit				
002	2 bits				
c7d9 0010	Response delay time <ul style="list-style-type: none"> • Response from the controller can be delayed after receiving command from the host computer. • Setting range: 0 to 1000 ms 				
58_b 000	SVTC bias <ul style="list-style-type: none"> • By connecting to Shinko programmable controllers, digital SV via the SVTC command can be received from programmable controllers. Shinko programmable controllers: PC-900, PCD-33A with the SVTC (SV digital transmission) option PCA1, PCB1 (When 'SV digital transmission' is selected in [Communication protocol]) Refer to Section '8. SV Digital Transmission' on p. 50. • SV adds SVTC bias value to the value received by the SVTC command. • Setting range: $\pm 20\%$ of input span DC voltage, current inputs: $\pm 20\%$ of scaling span (*) Available only when 'SV digital reception (Shinko protocol)' is selected in [Communication protocol]. 				

(*) The placement of the decimal point follows the selection.

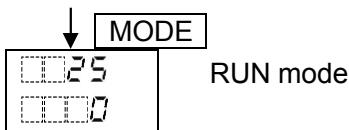

Now, settings are complete.

4. Communication Procedure

Communication starts with command transmission from the host computer (hereafter Master), and ends with the response of the PCB1 (hereafter Slave).

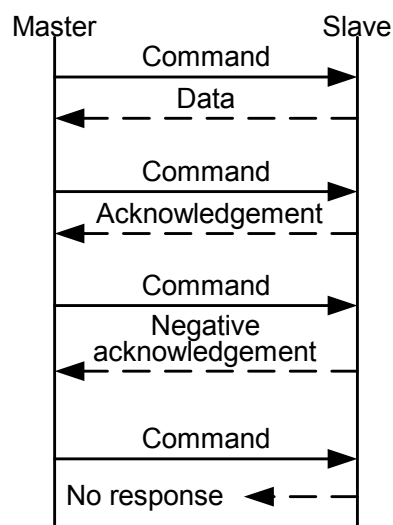

(Fig. 4-1)

• Response with data

When the master sends the Read command, the slave responds with the corresponding set value or current status.

• Acknowledgement

When the master sends the Write command, the slave responds by sending the acknowledgement after the processing is terminated.

• Negative acknowledgement

When the master sends a non-existent command or value out of the setting range, the slave returns a negative acknowledgement.

• No response

The slave will not respond to the master in the following cases:

- Global address (Shinko protocol) is set.
- Broadcast address (Modbus protocol) is set.
- Communication error (framing error, parity error)
- Checksum error (Shinko protocol), LRC discrepancy (Modbus ASCII mode), CRC-16 discrepancy (Modbus RTU mode)

Communication timing of the RS-485

Master Side (Take note while programming)

When the master starts transmission through the RS-485 communication line, the master is arranged so as to provide an idle status (mark status) transmission period of 1 or more characters before sending the command to ensure synchronization on the receiving side.

Set the program so that the master can disconnect the transmitter from the communication line within a 1 character transmission period after sending the command in preparation for reception of the response from the slave.

To avoid collision of transmissions between the master and the slave, send the next command after carefully checking that the master has received the response.

If a response to the command is not returned due to communication errors, set the Retry Processing to send the command again. (It is recommended to execute Retry twice or more.)

Slave Side

When the slave starts transmission through the RS-485 communication line, the slave is arranged so as to provide an idle status (mark status) transmission period of 1 ms or more (*) before sending the response to ensure synchronization on the receiving side.

The slave is arranged so as to disconnect the transmitter from the communication line within a 1 character transmission period after sending the response.

(*) Can be set in [Response delay time] within a range of 0 to 1000 ms. (See p. 5.)

5. Shinko Protocol

5.1 Transmission Mode

Shinko protocol is composed of ASCII.

Hexadecimal (0 to 9, A to F), which is divided into high order (4-bit) and low order (4-bit) out of 8-bit binary data in command is transmitted as ASCII characters.

Data format Start bit: 1 bit

Data bit: 7 bits (8 bits) Selectable

Parity: Even (No parity, Odd) Selectable

Stop bit: 1 bit (2 bits) Selectable

Error detection: Checksum

5.2 Command Configuration

All commands are composed of ASCII.

The data (set value, decimal number) is represented by a hexadecimal number.

The negative numbers are represented in 2's complement.

Numerals written below the command represent number of characters.

(1) Write command

Header (02H)	Address	Sub address (20H)	Command type (50H)	Data item	Data	Checksum	Delimiter (03H)
1	1	1	1	4	4	2	1

(2) Read command

Header (02H)	Address	Sub address (20H)	Command type (20H)	Data item	Checksum	Delimiter (03H)
1	1	1	1	4	2	1

(3) Response with data

Header (06H)	Address	Sub address (20H)	Command type (20H)	Data item	Data	Checksum	Delimiter (03H)
1	1	1	1	4	4	2	1

(4) Acknowledgement

Header (06H)	Address	Checksum	Delimiter (03H)
1	1	2	1

(5) Negative acknowledgement

Header (15H)	Address	Error code	Checksum	Delimiter (03H)
1	1	1	2	1

Header: Control code to represent the beginning of the command or the response. ASCII is used.

Write command, Read command: STX (02H) fixed

Response with data, Acknowledgement: ACK (06H) fixed

Negative acknowledgement: NAK (15H) fixed

Instrument number (Address): Numbers by which the master discerns each slave.

Instrument number 0 to 94 and Global address 95.

ASCII (20H to 7FH) is used by adding 20H to instrument numbers 0 to 95 (00H to 5FH).

95 (7FH) is called Global address, which is used when the same command is sent to all the slaves connected. However, the response is not returned.

Sub address: 20H fixed

Command type: Code to discern Write command and Read command.

Data Read: 20H

Data Write: 50H

Data item: Classification of the command object.

Composed of 4-digit hexadecimal numbers, using ASCII.

Refer to '7. Communication Command Table'. (pp. 24 to 43)

Data: The contents of data (values) differ depending on the Write command.

Composed of 4-digit hexadecimal numbers, using ASCII.

Refer to '7. Communication Command Table'. (pp. 24 to 43)

Checksum: 2-character data to detect communication errors.

Refer to '5.3 Checksum Calculation' on p. 9.

Delimiter: Control code to represent the end of command.

ASCII code ETX (03H) fixed

Error code: Represents an error type using ASCII.

Error Code	Contents
1 (31H)	Non-existent command
2 (32H)	Not used
3 (33H)	Value outside the setting range
4 (34H)	Status unable to be written (e.g. AT is performing.)
5 (35H)	During setting mode by keypad operation

5.3 Checksum Calculation

Checksum is used to detect receiving errors in the command or data.

Set the program for the master side as well to calculate the checksum of the response data from the slaves so that communication errors can be checked.

The ASCII code (hexadecimal) corresponding to the characters which range from the address to that before the checksum is converted to binary notation, and the total value is calculated.

The lower one byte of the total value is converted to 2's complement, and then to hexadecimal numbers, that is, ASCII code for the checksum.

- 1's complement: Reverse each binary bit. 0 will become 1 and vice versa.
- 2's complement: Add 1 to 1's complement.

[Example of checksum calculation]

Pattern 1, Step 1, Step SV (2100H) is written to 600°C (0258H)

Address (instrument number): 0 (20H)

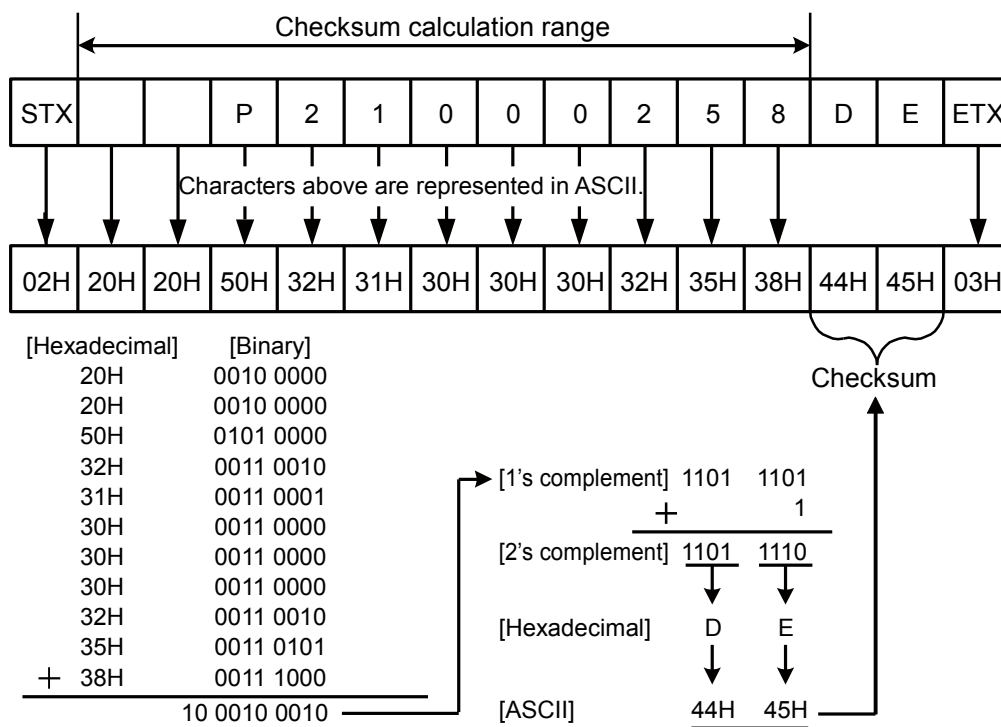

(Fig. 5.3-1)

5.4 Command Example

Numerals written below the command represent number of characters.

(1) Read [Address 1, PV]

- Read command from the master

Header (02H)	Address (21H)	Sub address (20H)	Command type (20H)	Data item [9000H] (39H 30H 30H 30H)	Checksum (44H 36H)	Delimiter (03H)
1	1	1	1	4	2	1

- A response from the slave in normal status [When PV=500°C (01F4H)]

Header (06H)	Address (21H)	Sub address (20H)	Command type (20H)	Data item [9000H] (39H 30H 30H 30H)	Data [01F4H] (30H 31H 46H 34H)	Checksum (46H 42H)	Delimiter (03H)
1	1	1	1	4	4	2	1

(2) Write [Address 1, Pattern 1, Step 1, Step SV]

- Write command from the master [When writing Step SV to 500°C (01F4H)]

Header (02H)	Address (21H)	Sub address (20H)	Command type (50H)	Data item [2100H] (32H 31H 30H 30H)	Data [01F4H] (30H 31H 46H 34H)	Checksum (44H 31H)	Delimiter (03H)
1	1	1	1	4	4	2	1

- A response from the slave in normal status

Header (06H)	Address (21H)	Checksum (44H 46H)	Delimiter (03H)
1	1	2	1

(3) Read [Address 1, Pattern 1, Step 1, Step SV]

- Read command from the master

Header (02H)	Address (21H)	Sub address (20H)	Command type (20H)	Data item [2100H] (32H 31H 30H 30H)	Checksum (44H 43H)	Delimiter (03H)
1	1	1	1	4	2	1

- A response from the slave in normal status [When Step SV=500°C (01F4H)]

Header (06H)	Address (21H)	Sub address (20H)	Command type (20H)	Data item [2100H] (32H 31H 30H 30H)	Data [01F4H] (30H 31H 46H 34H)	Checksum (30H 31H)	Delimiter (03H)
1	1	1	1	4	4	2	1

6. Modbus Protocol

6.1 Transmission Mode

There are 2 transmission modes (ASCII and RTU) in Modbus protocol.

6.1.1 ASCII Mode

Hexadecimal (0 to 9, A to F), which is divided into high order (4-bit) and low order (4-bit) out of 8-bit binary data in command is transmitted as ASCII characters.

Data format Start bit: 1 bit
 Data bit: 7 bits (8 bits) (Selectable)
 Parity: Even (No parity, Odd) (Selectable)
 Stop bit: 1 bit (2 bits) (Selectable)
 Error detection : LRC (Longitudinal Redundancy Check)

6.1.2 RTU Mode

8-bit binary data in command is transmitted as it is.

Data format Start bit: 1 bit
 Data bit: 8 bits
 Parity: No parity (Even, Odd) (Selectable)
 Stop bit: 1 bit (2 bits) (Selectable)
 Error detection: CRC-16 (Cyclic Redundancy Check)

6.2 Data Communication Interval

6.2.1 ASCII Mode

No communication interval limit between characters

6.2.2 RTU Mode

1.5 character transmission times or less

(Communication speed 9600 bps, 19200 bps: 1.5 character transmission times

Communication speed 38400 bps: 750 μ s)

To transmit continuously, an interval between characters which consist of one message, must be within 1.5 character transmission times.

If an interval lasts longer than 1.5 character transmission times, the PCB1 assumes that transmission from the master is finished, which results in a communication error, and will not return a response.

6.3 Message Configuration

6.3.1 ASCII Mode

ASCII mode message is configured to start by Header [: (colon) (3AH)] and end by Delimiter [CR (carriage return) (0DH) + LF (Line feed) (0AH)].

Data section: Max. 2 x 252 characters

Header (:)	Slave address	Function code	Data	Error check LRC	Delimiter (CR)	Delimiter (LF)
---------------	------------------	------------------	------	--------------------	-------------------	-------------------

6.3.2 RTU Mode

RTU mode is configured to start after idle time is processed for more than 3.5 character transmissions, and end after idle time is processed for more than 3.5 character transmissions.

(Communication speed 9600 bps, 19200 bps: 3.5 character transmission times

Communication speed 38400 bps: 1.75 ms)

Data section: Max. 252 bytes

3.5 idle characters	Slave address	Function code	Data	Error check CRC-16	3.5 idle characters
------------------------	------------------	------------------	------	-----------------------	------------------------

(1) Slave Address

Slave address is an individual instrument number on the slave side, and is set within the range 0 to 95 (00H to 5FH). The master identifies slaves by the slave address of the requested message. The slave informs the master which slave is responding to the master by placing its own address in the response message.

Slave address 0 (00H, Broadcast address) can identify all the slaves connected. However, slaves do not respond.

(2) Function Code

The function code is the command code for the slave to undertake one of the following actions.

Function Code	Contents
03 (03H)	Reads a single or multiple piece(s) of data from slave(s). Amount of data: Max. 100 (*)
06 (06H)	Writes a single piece of data to slave(s).
16 (10H)	Writes multiple pieces of data to slave(s). (Amount of data: Max. 100)

(*) PCD-33A commands do not correspond to multiple pieces of data reading. Amount of data: 1

The function code is used to discern whether the response is normal (acknowledgement) or if any error (negative acknowledgement) has occurred when the slave returns the response message to the master.

When acknowledgement is returned, the slave simply returns the original function code.

When negative acknowledgement is returned, the MSB of the original function code is set as 1 for the response.

For example, if the master sends request message setting 13H to the function code by mistake, slave returns 93H by setting the MSB to 1, because the former is an illegal function.

For negative acknowledgement, the exception codes below are set to the data of the response message, and returned to the master in order to inform it of what kind of error has occurred.

Exception Code	Contents
1 (01H)	Illegal function (Non-existent function)
2 (02H)	Illegal data address (Non-existent data address) (*)
3 (03H)	Illegal data value (Value out of the setting range)
17 (11H)	Shinko protocol error code 4 (Status unable to be written. (e.g.) AT is performing.)
18 (12H)	Shinko protocol error code 5 (During setting mode by keypad operation)

(*) For non-existent data address, if multiple pieces of data are read, acknowledgement will be returned (but data is 0).
If multiple pieces of data are written, acknowledgement will be returned, and data will be discarded.

(3) Data

Data differs depending on the function code.

A request message from the master is composed of a data item, amount of data and setting data.

A response message from the slave is composed of the number of bytes, data and exception codes in negative acknowledgements, corresponding to the request message.

The effective range of data is -32768 to 32767 (8000H to 7FFFH).

Refer to Section "7. Communication Command Table" (pp.24 to 43).

(4) Error Check

ASCII Mode

After calculating LRC (Longitudinal Redundancy Check) from the slave address to the end of data, the calculated 8-bit data is converted to two ASCII characters, and are appended to the end of message.

How to Calculate LRC

- ① Create a message in RTU mode.
- ② Add all the values from the slave address to the end of data. This is assumed as X.
- ③ Make a complement for X (bit reverse). This is assumed as X.
- ④ Add a value of 1 to X. This is assumed as X.
- ⑤ Set X as an LRC to the end of the message.
- ⑥ Convert the whole message to ASCII characters.

RTU Mode

After calculating CRC-16 (Cyclic Redundancy Check) from the slave address to the end of the data, the calculated 16-bit data is appended to the end of message in sequence from low order to high order.

How to calculate CRC-16

In the CRC-16 system, the information is divided by the polynomial series. The remainder is added to the end of the information and transmitted. The generation of a polynomial series is as follows.

(Generation of polynomial series: $X^{16} + X^{15} + X^2 + 1$)

- ① Initialize the CRC-16 data (assumed as X) (FFFFH).
- ② Calculate exclusive OR (XOR) with the 1st data and X. This is assumed as X.
- ③ Shift X one bit to the right. This is assumed as X.
- ④ When a carry is generated as a result of the shift, XOR is calculated by X of ③ and the fixed value (A001H). This is assumed as X. If a carry is not generated, go to step ⑤.
- ⑤ Repeat steps ③ and ④ until shifting 8 times.
- ⑥ XOR is calculated with the next data and X. This is assumed as X.
- ⑦ Repeat steps ③ to ⑤.
- ⑧ Repeat steps ③ to ⑤ up to the final data.
- ⑨ Set X as CRC-16 to the end of message in sequence from low order to high order.

6.4 Message Example

6.4.1 ASCII Mode

Numerals written below the command represent the number of characters.

(1) Read [Slave address 1, PV]

- A request message from the master

Header (3AH)	Slave address (30H 31H)	Function code (30H 33H)	Data item [9000H] (39H 30H 30H 30H)	Amount of data [0001H] (30H 30H 30H 31H)	Error check LRC (36H 42H)	Delimiter CR+LF (0DH 0AH)
1	2	2	4	4	2	2

- Response message from the slave in normal status [When PV=500°C (01F4H)]

Header (3AH)	Slave address (30H 31H)	Function code (30H 33H)	Number of response bytes [02H] (30H 32H)	Data [01F4H] (30H 31H 46H 34H)	Error check LRC (41H 30H)	Delimiter CR+LF (0DH 0AH)
1	2	2	2	4	2	2

(2) Write [Slave address 1, Pattern 1, Step 1, Step SV]

- A request message from the master [When writing Step SV to 500°C (01F4H)]

Header (3AH)	Slave address (30H 31H)	Function code (30H 36H)	Data item [2100H] (32H 31H 30H 30H)	Data [01F4H] (30H 31H 46H 34H)	Error check LRC (45H 33H)	Delimiter CR+LF (0DH 0AH)
1	2	2	4	4	2	2

- Response message from the slave in normal status

Header (3AH)	Slave address (30H 31H)	Function code (30H 36H)	Data item [2100H] (32H 31H 30H 30H)	Data [01F4H] (30H 31H 46H 34H)	Error check LRC (45H 33H)	Delimiter CR+LF (0DH 0AH)
1	2	2	4	4	2	2

- Response message from the slave in exception (error) status (When a value out of the setting range is set)
The function code MSB is set to 1 for the response message in exception (error) status [86H (38H 36H)].
The exception code 03H (30H 33H: Value out of the setting range) is returned (error).

Header (3AH)	Slave address (30H 31H)	Function code (38H 36H)	Exception code [03H] (30H 33H)	Error check LRC (37H 36H)	Delimiter CR+LF (0DH 0AH)
1	2	2	2	2	2

(3) Read [Slave address 1, Pattern 1, Step 1, Step SV]

- A request message from the master

Header (3AH)	Slave address (30H 31H)	Function code (30H 33H)	Data item [2100H] (32H 31H 30H 30H)	Amount of data [0001H] (30H 30H 30H 31H)	Error check LRC (44H 41H)	Delimiter CR+LF (0DH 0AH)
1	2	2	4	4	2	2

- Response message from the slave in normal status [When Step SV=500°C (01F4H)]

Header (3AH)	Slave address (30H 31H)	Function code (30H 33H)	Number of response bytes [02H] (30H 32H)	Data [01F4H] (30H 31H 46H 34H)	Error check LRC (30H 35H)	Delimiter CR+LF (0DH 0AH)
1	2	2	2	4	2	2

- Response message from the slave in exception (error) status (When data item is incorrect)
The function code MSB is set to 1 for the response message in exception (error) status [83H (38H 33H)].
The exception code 02H (30H 32H: Non-existent data address) is returned (error).

Header (3AH)	Slave address (30H 31H)	Function code (38H 33H)	Exception code [02H] (30H 32H)	Error check LRC (37H 41H)	Delimiter CR+LF (0DH 0AH)
1	2	2	2	2	2

(4) Write/Read Program Pattern Data

Example of program pattern setting

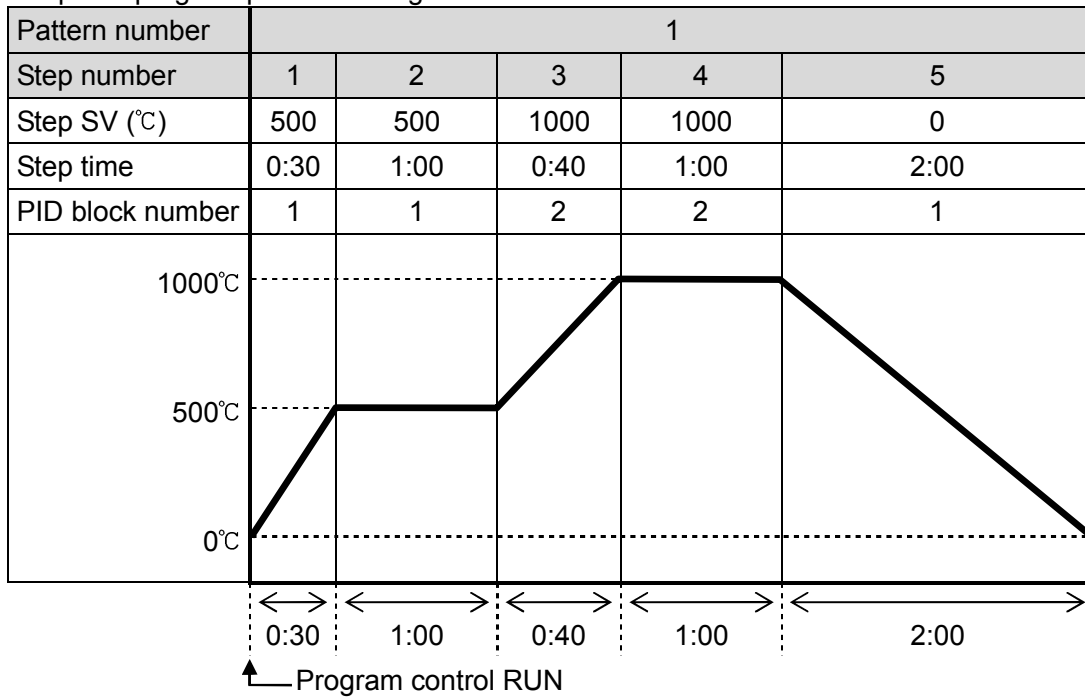

(Fig. 6.4.1-1)

When writing the above program pattern, Data in the message becomes as follows.

Amount of data: 15 (000FH)

Number of bytes: 30 (1EH)

Data is converted to hexadecimal.

	Data Item	Data	Data (Converted to Hexadecimal)
2100H	Step 1 SV	500°C	01F4H
2101H	Step 1 time	30 minutes (0:30)	001EH
2102H	Step 1 PID block number	1	0001H
2103H	Step 2 SV	500°C	01F4H
2104H	Step 2 time	60 minutes (1:00)	003CH
2105H	Step 2 PID block number	1	0001H
2106H	Step 3 SV	1000°C	03E8H
2107H	Step 3 time	40 minutes (0:40)	0028H
2108H	Step 3 PID block number	2	0002H
2109H	Step 4 SV	1000°C	03E8H
210AH	Step 4 time	60 minutes (1:00)	003CH
210BH	Step 4 PID block number	2	0002H
210CH	Step 5 SV	0°C	0000H
210DH	Step 5 time	120 minutes (2:00)	0078H
210EH	Step 5 PID block number	1	0001H

- A request message from the master (When writing the program pattern data on p. 15)

Header (3AH)	Slave address (30H 31H)	Function code (31H 30H)	Data item [2100H] (32H 31H 30H 30H)	Amount of data [000FH] (30H 30H 30H 46H)	Number of bytes [1EH] (31H 45H)
1	2	2	4	4	2

Data [01F4001E000101F4003C000103E80028000203E8003C0002000000780001H] (30H 31H 46H 34H 30H 30H 31H 45H 30H 30H 30H 30H 37H 38H 30H 30H 30H 31H)
60

Error check LRC (41H 34H)	Delimiter CR+LF (0DH 0AH)
2	2

- A response message from the slave in normal status

Header (3AH)	Slave address (30H 31H)	Function code (31H 30H)	Data item [2100H] (32H 31H 30H 30H)	Data [000FH] (30H 30H 30H 46H)	Error check LRC (42H 46H)	Delimiter CR+LF (0DH 0AH)
1	2	2	4	4	2	2

(5) Read (Slave address 1, Program pattern data) (Read multiple pieces of data)

- A request message from the master (When reading the program pattern data on p.15)

Header (3AH)	Slave address (30H 31H)	Function code (30H 33H)	Data item [2100H] (32H 31H 30H 30H)	Amount of data [000FH] (30H 30H 30H 46H)	Error check LRC (43H 43H)	Delimiter CR+LF (0DH 0AH)
1	2	2	4	4	2	2

- Response message from the slave in normal status

Header (3AH)	Slave address (30H 31H)	Function code (30H 33H)	Number of response bytes [1EH] (31H 45H)
1	2	2	2

Data [01F4001E000101F4003C000103E80028000203E8003C0002000000780001H] (30H 31H 46H 34H 30H 30H 31H 45H 30H 30H 30H 30H 37H 38H 30H 30H 30H 31H)
60

Error check LRC (45H 31H)	Delimiter CR+LF (0DH 0AH)
2	2

6.4.2 RTU Mode

Numerals written below the command represent number of characters.

(1) Read [Slave address 1, PV]

- A request message from the master

3.5 idle characters	Slave address (01H)	Function code (03H)	Data item (9000H)	Amount of data (0001H)	Error check CRC-16 (A90AH)	3.5 idle characters
	1	1	2	2	2	

- Response message from the slave in normal status [When PV is 500°C (01F4H)]

3.5 idle characters	Slave address (01H)	Function code (03H)	Number of response bytes (02H)	Data (01F4H)	Error check CRC-16 (B853H)	3.5 idle characters
	1	1	1	2	2	

(2) Write [Slave address 1, Pattern 1, Step 1, Step SV]

- A request message from the master [When Step SV is written to 500°C (01F4H)]

3.5 idle characters	Slave address (01H)	Function code (06H)	Data item (2100H)	Data (01F4H)	Error check CRC-16 (83E1H)	3.5 idle characters
	1	1	2	2	2	

- Response message from the slave in normal status

3.5 idle characters	Slave address (01H)	Function code (06H)	Data item (2100H)	Data (01F4H)	Error check CRC-16 (83E1H)	3.5 idle characters
	1	1	2	2	2	

- Response message from the slave in exception (error) status (When a value out of the setting range is set)
The function code MSB is set to 1 for the response message in exception (error) status, and 86H is returned.

The Exception code 03H (Value out of the setting range) is returned (error).

3.5 idle characters	Slave address (01H)	Function code (86H)	Exception code (03H)	Error check CRC-16 (0261H)	3.5 idle characters
	1	1	1	2	

(3) Read [Slave address 1, Pattern 1, Step 1, Step SV]

- A request message from the master

3.5 idle characters	Slave address (01H)	Function code (03H)	Data item (2100H)	Data (0001H)	Error check CRC-16 (8E36H)	3.5 idle characters
	1	1	2	2	2	

- Response message from the slave in normal status [When Step SV is 500°C (01F4H)]

3.5 idle characters	Slave address (01H)	Function code (03H)	Number of response bytes (02H)	Data (01F4H)	Error check CRC-16 (B853H)	3.5 idle characters
	1	1	1	2	2	

- Response message from the slave in exception (error) status (When data item is incorrect)
The function code MSB is set to 1 for the response message in exception (error) status, and 83H is returned. The Exception code 02H (Non-existent data address) is returned (error).

3.5 idle characters	Slave address (01H)	Function code (83H)	Exception code (02H)	Error check CRC-16 (C0F1H)	3.5 idle characters
	1	1	1	2	

(4) Write/Read Program pattern data

Program pattern setting example

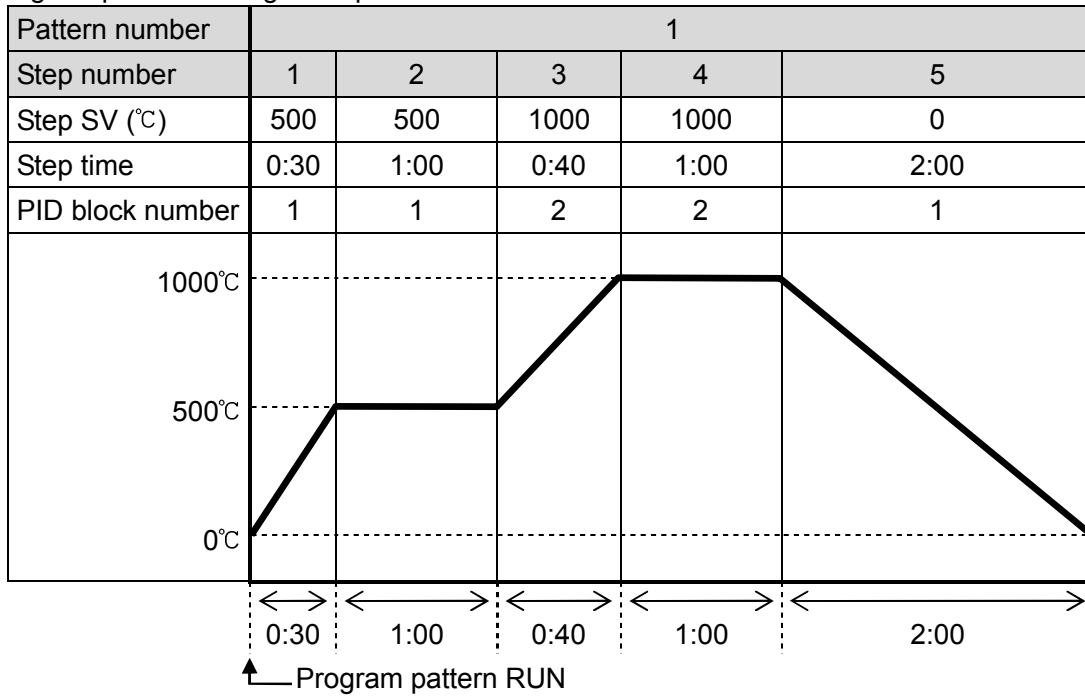

(Fig. 6.4.2-1)

When writing the above program pattern, Data in the message becomes as follows.

Amount of data: 15 (000FH)

Number of bytes: 30 (1EH)

Data is converted to hexadecimal.

Data Item		Data	Data (Converted to Hexadecimal)
2100H	Step 1 SV	500°C	01F4H
2101H	Step 1 time	30 minutes (0:30)	001EH
2102H	Step 1 PID block number	1	0001H
2103H	Step 2 SV	500°C	01F4H
2104H	Step 2 time	60 minutes (1:00)	003CH
2105H	Step 2 PID block number	1	0001H
2106H	Step 3 SV	1000°C	03E8H
2107H	Step 3 time	40 minutes (0:40)	0028H
2108H	Step 3 PID block number	2	0002H
2109H	Step 4 SV	1000°C	03E8H
210AH	Step 4 time	60 minutes (1:00)	003CH
210BH	Step 4 PID block number	2	0002H
210CH	Step 5 SV	0°C	0000H
210DH	Step 5 time	120 minutes (2:00)	0078H
210EH	Step 5 PID block number	1	0001H

- A request message from the master (When writing the program pattern data on p.18)

3.5 idle characters	Slave address (01H)	Function code (10H)	Data item (2100H)	Amount of data (000FH)	Number of bytes (1EH)
	1	1	2	2	1

Data
(01F4001E000101F4003C000103E80028000203E8003C0002000000780001H)
30

Error check CRC-16 (9A89H)	3.5 idle characters
2	

- Response message from the slave in normal status

3.5 idle characters	Slave address (01H)	Function code (10H)	Data item (2100H)	Data (000FH)	Error check CRC-16 (8A31H)	3.5 idle characters
	1	1	2	2	2	

(5) Read (Slave address 1, Program pattern data) (Read multiple pieces of data)

- A request message from the master (When reading the program pattern data on p. 18)

3.5 idle characters	Slave address (01H)	Function code (03H)	Data item (2100H)	Amount of data (000FH)	Error check CRC-16 (0FF2H)	3.5 idle characters
	1	1	2	2	2	

- Response message from the slave in normal status

3.5 idle characters	Slave address (01H)	Function code (03H)	Number of response bytes (1EH)
	1	1	1

Data
(00C8003C000A00C800780000012C001E000A012C003C0000000000780000H)
30

Error check CRC-16 (26E0H)	3.5 idle characters
2	

6.5 Diagnostics Function

Modbus protocol has the following diagnostics functions.

- Echoes back the request message.
- Reads device identification information.

6.5.1 Message Configuration

ASCII mode

Header (:)	Slave address	Function code	Data	Error check LRC	Delimiter (CR)	Delimiter (LF)
---------------	------------------	------------------	------	--------------------	-------------------	-------------------

RTU mode

3.5 idle characters	Slave address	Function code	Data	Error check CRC-16	3.5 idle characters
------------------------	------------------	------------------	------	-----------------------	------------------------

(1) Slave address:

Slave address is an individual instrument number on the slave side, and is set within the range 1 to 95 (01H to 5FH).

The master identifies slaves by the slave address of the requested message.

The slave informs the master which slave is responding to the master by placing its own address in the response message.

Diagnostics function is disabled for the Slave address 0 (00H, broadcast address).

(2) Function code:

The function code is the command code for the slave to undertake the following action types.

Type	Function Code	Sub-function Code	Contents
Diagnostics	08 (08H)	00 (0000H)	Echoes back the request message.
	43 (2BH)	14 (0EH)	Reads device identification information.

Function code is used to discern whether the response is normal (acknowledgement) or if any error (negative acknowledgement) has occurred when the slave returns the response message to the master. When acknowledgement is returned, the slave simply returns the original function code.

When negative acknowledgement is returned, the MSB of the original function code is set as 1 for the response.

For example, when the master sends request message setting 0FH to the sub-function code by mistake, slave returns ABH by setting the MSB to 1, because the former is a non-existent sub-function code.

For negative acknowledgement, the exception codes below are set to the data of the response message, and returned to the master in order to inform it of what kind of error has occurred.

Exception Code	Contents
1 (01H)	Illegal function (Non-existent function) Sub-function code is not correct.
2 (02H)	Illegal data address (Non-existent data address) For function code 43: Object ID is any value other than 00, 01, 02.
3 (03H)	Illegal data value (Value out of the setting range) For function code 08: Data is less than 1, or has exceeded 100. For function code 43: Read Device ID code is any value other than 01, 04.

(3) Data

Data differs depending on the function code.

For the Function code 08 (08H), a request message from the master side is composed of 'Sub-function code 2 Bytes (0000H)' and 'Data n x 2 Bytes'. [n: Amount of data (Max. 100)]

In normal status, a response message from the slave side is the same as the request message.

Function code	1 Byte	08H
Sub-function code	1 Byte	0000H fixed
Data	n x 2 Bytes	Random value (Max. 100)

For Function code 43 (2BH), the request message from the master side is composed of Sub-function code 14 (0EH), Read Device ID code and Object ID.

Function code	1 Byte	2BH	
Sub-function code (MEI type)	1 Byte	0EH	
Read Device ID code (Corresponds to Basic category)	1 Byte	01H/04H	
Object ID	1 Byte	00	Vendor name SHINKO TECHNOS CO., LTD.
		01	Product code (model) (e.g.) PCB1R00-11
		02	Version number (D, MP / T, MP) (e.g.) Dxx-xxxx-xxMPxxxx-xx, Txxxx-xxMPxxxx-xx

Response message from the slave is composed of Sub-function code 14 (0EH) (for request), Read Device ID code and Object ID.

Function code	1 Byte	2BH	
Sub-function code (MEI type)	1 Byte	0EH	
Data	Read Device ID code	1 Byte	01H/04H
	Conformity level	1 Byte	01H/81H
	More Follows	1 Byte	00H/FFH
	Next Object ID	1 Byte	Object ID number
	Number of Objects	1 Byte	
	List of Object ID	1 Byte	
	List of Object length	1 Byte	
	List of Object value	Object length	

For the response message (negative acknowledgement), an exception code is set and returned.

Function code	1 Byte	ABH
Exception code	1 Byte	01H/02H/03H/04H

(4) Error check:

16-bit data to detect communication errors.

Refer to Sections '6.3 Message Configuration (4) Error Check (p.13).

6.5.2 Message Example

Message examples in RTU mode are shown below.

Numerals written below the command represent the number of characters.

(1) Echo back Slave address 1, Request message

- A request message from the master [Test data 200 (00C8H), 60 (003CH), 10 (000AH)]

3.5 idle characters	Slave address (01H)	Function code (08H)	Sub-function code (0000H)	Data (00C8003C000AH)	Error check CRC-16 (E7D9H)	3.5 idle characters
	1	1	2	n x 2	2	

- Response message from the slave in normal status (Echoes back the same message.)

3.5 idle characters	Slave address (01H)	Function code (08H)	Sub-function code (0000H)	Data (00C8003C000AH)	Error check CRC-16 (E7D9H)	3.5 idle characters
	1	1	2	n x 2	2	

(2) Read Slave address 1, Device identification information (Vendor name)

- A request message from the master

3.5 idle characters	Slave address (01H) 1	Function code (2BH) 1	Sub-function code (0EH) 1	Data (0400H) 2	Error check CRC-16 (7327H) 2	3.5 idle characters
---------------------	--------------------------	--------------------------	------------------------------	-------------------	---------------------------------	---------------------

- Response message from the slave in normal status (SHINKO TECHNOS CO., LTD.)

3.5 idle characters	Slave address (01H) 1	Function code (2BH) 1	Sub-function code (0EH) 1
---------------------	--------------------------	--------------------------	------------------------------

Data (048100000100185348494E4B4F205444543484E4F5320434F2E2C204C54442EH) 31
--

3.5 idle characters	Error check CRC-16 (1C54H) 2	3.5 idle characters
---------------------	---------------------------------	---------------------

Data in the response message becomes as follows.

Data	Read Device ID code	1 Byte	04H
	Conformity level	1 Byte	81H
	More Follows	1 Byte	00H
	Next Object ID	1 Byte	00H
	Number of Objects	1 Byte	01H
	List of Object ID	1 Byte	00H
	List of Object length	1 Byte	24(18H)
	List of Object value	Object length	S(53H)
			H(48H)
			I(49H)
			N(4EH)
			K(4BH)
			O(4FH)
			(20H)
			T(54H)
			E(45H)
			C(43H)
			H(48H)
			N(4EH)
			O(4FH)
			S(53H)
			(20H)
			C(43H)
			O(4FH)
			.(2EH)
			.(2CH)
			(20H)
		L(4CH)	
		T(54H)	
		D(44H)	
		.(2EH)	

(3) Read Slave address 1, Device identification information (Product code)

- A request message from the master

3.5 idle characters	Slave address (01H)	Function code (2BH)	Sub-function code (0EH)	Data (0401H)	Error check CRC-16 (B2E7H)	3.5 idle characters
	1	1	1	2	2	

- Response message from the slave in normal status (PCB1R00-11)

3.5 idle characters	Slave address (01H)	Function code (2BH)	Sub-function code (0EH)			3.5 idle characters
	1	1	1			
				Data (0481000001010A504342315230302D3131H)	Error check CRC-16 (EF0BH)	3.5 idle characters
				17	2	

Data in the response message becomes as follows.

Data	Read Device ID code	1 Byte	04H
	Conformity level	1 Byte	81H
	More Follows	1 Byte	00H
	Next Object ID	1 Byte	00H
	Number of Objects	1 Byte	01H
	List of Object ID	1 Byte	01H
	List of Object length	1 Byte	10(0AH)
	List of Object value	Object length	P(50H)
			C(43H)
			B(42H)
			1(31H)
			R(52H)
			0(30H)
			0(30H)
			-(2DH)
		1(31H)	
		1(31H)	

- Response message from the slave in exception (error) status [when Sub-function code (MEI type) is incorrect]

The function code MSB is set to 1 for the response message in exception (error) status, and ABH is returned.

Exception code 01H (Non-existent function) is returned (error).

3.5 idle characters	Slave address (01H)	Function code (ABH)	Exception code (01H)	Error check CRC-16 (9EF0H)	3.5 idle characters
	1	1	1	2	

7. Communication Command Table

7.1 Shinko Protocol / Modbus ASCII / Modbus RTU

7.1.1 Read/Write Command

(1) Pattern Setting Mode Item

Shinko Command Type	Modbus Function Code	Data Item		Data
20/50H	03/06/10H	2x00H	Step 1 SV	Set value, Decimal point ignored
20/50H	03/06/10H	2x01H	Step 1 time	Set value
20/50H	03/06/10H	2x02H	Step 1 PID block number	0001H: Block 1 0002H: Block 2 0003H: Block 3 0004H: Block 4 0005H: Block 5 0006H: Block 6 0007H: Block 7 0008H: Block 8 0009H: Block 9 000AH: Block 10
20/50H	03/06/10H	2x03H	Step 2 SV	Set value, Decimal point ignored
20/50H	03/06/10H	2x04H	Step 2 time	Set value
20/50H	03/06/10H	2x05H	Step 2 PID block number	0001H: Block 1 0002H: Block 2 0003H: Block 3 0004H: Block 4 0005H: Block 5 0006H: Block 6 0007H: Block 7 0008H: Block 8 0009H: Block 9 000AH: Block 10
20/50H	03/06/10H	2x06H	Step 3 SV	Set value, Decimal point ignored
20/50H	03/06/10H	2x07H	Step 3 time	Set value
20/50H	03/06/10H	2x08H	Step 3 PID block number	0001H: Block 1 0002H: Block 2 0003H: Block 3 0004H: Block 4 0005H: Block 5 0006H: Block 6 0007H: Block 7 0008H: Block 8 0009H: Block 9 000AH: Block 10
20/50H	03/06/10H	2x09H	Step 4 SV	Set value, Decimal point ignored
20/50H	03/06/10H	2x0AH	Step 4 time	Set value

Shinko Command Type	Modbus Function Code	Data Item		Data
20/50H	03/06/10H	2x0BH	Step 4 PID block number	0001H: Block 1 0002H: Block 2 0003H: Block 3 0004H: Block 4 0005H: Block 5 0006H: Block 6 0007H: Block 7 0008H: Block 8 0009H: Block 9 000AH: Block 10
20/50H	03/06/10H	2x0CH	Step 5 SV	Set value, Decimal point ignored
20/50H	03/06/10H	2x0DH	Step 5 time	Set value
20/50H	03/06/10H	2x0EH	Step 5 PID block number	0001H: Block 1 0002H: Block 2 0003H: Block 3 0004H: Block 4 0005H: Block 5 0006H: Block 6 0007H: Block 7 0008H: Block 8 0009H: Block 9 000AH: Block 10
20/50H	03/06/10H	2x0FH	Step 6 SV	Set value, Decimal point ignored
20/50H	03/06/10H	2x10H	Step 6 time	Set value
20/50H	03/06/10H	2x11H	Step 6 PID block number	0001H: Block 1 0002H: Block 2 0003H: Block 3 0004H: Block 4 0005H: Block 5 0006H: Block 6 0007H: Block 7 0008H: Block 8 0009H: Block 9 000AH: Block 10
20/50H	03/06/10H	2x12H	Step 7 SV	Set value, Decimal point ignored
20/50H	03/06/10H	2x13H	Step 7 time	Set value
20/50H	03/06/10H	2x14H	Step 7 PID block number	0001H: Block 1 0002H: Block 2 0003H: Block 3 0004H: Block 4 0005H: Block 5 0006H: Block 6 0007H: Block 7 0008H: Block 8 0009H: Block 9 000AH: Block 10
20/50H	03/06/10H	2x15H	Step 8 SV	Set value, Decimal point ignored
20/50H	03/06/10H	2x16H	Step 8 time	Set value

Shinko Command Type	Modbus Function Code	Data Item		Data
20/50H	03/06/10H	2x17H	Step 8 PID block number	0001H: Block 1 0002H: Block 2 0003H: Block 3 0004H: Block 4 0005H: Block 5 0006H: Block 6 0007H: Block 7 0008H: Block 8 0009H: Block 9 000AH: Block 10
20/50H	03/06/10H	2x18H	Step 9 SV	Set value, Decimal point ignored
20/50H	03/06/10H	2x19H	Step 9 time	Set value
20/50H	03/06/10H	2x1AH	Step 9 PID block number	0001H: Block 1 0002H: Block 2 0003H: Block 3 0004H: Block 4 0005H: Block 5 0006H: Block 6 0007H: Block 7 0008H: Block 8 0009H: Block 9 000AH: Block 10
20/50H	03/06/10H	2x1BH	Step 10 SV	Set value, Decimal point ignored
20/50H	03/06/10H	2x1CH	Step 10 time	Set value
20/50H	03/06/10H	2x1DH	Step 10 PID block number	0001H: Block 1 0002H: Block 2 0003H: Block 3 0004H: Block 4 0005H: Block 5 0006H: Block 6 0007H: Block 7 0008H: Block 8 0009H: Block 9 000AH: Block 10
20/50H	03/06/10H	2x1EH	Number of repetitions	Set value
20/50H	03/06/10H	2x1FH	Pattern link	0000H: Pattern link Disabled 0001H: Pattern link Enabled

Data item:

16³ digit: Pattern setting mode item (2 fixed)

16² digit: Pattern number [1 to A (10)]

16¹, 16⁰ digits: Data item identification number (00 to 1F)

Data:

Calculate the step time using the smaller time unit at 7018H (Step time unit), then convert it to hexadecimal numbers.

Setting range: 00:00 to 99:59 (0 to 5999) (0000H to 176FH)]

(e.g.) • 1 hour 30 minutes → 90 minutes → 005AH

• 15 minutes 30 seconds → 930 seconds → 03A2H

---- (FFFFH): The step time is held, and Fixed value control is performed using the step SV.

(2) Event Setting Mode Item

Shinko Command Type	Modbus Function Code	Data Item		Data
20/50H	03/06/10H	3x00H	EV1 alarm value	Set value
20/50H	03/06/10H	3x01H	EV1 high limit alarm value	Set value
20/50H	03/06/10H	3x02H	TS1 output OFF time	Set value
20/50H	03/06/10H	3x03H	TS1 output ON time	Set value
20/50H	03/06/10H	3x04H	EV2 alarm value	Set value
20/50H	03/06/10H	3x05H	EV2 high limit alarm value	Set value
20/50H	03/06/10H	3x06H	TS2 output OFF time	Set value
20/50H	03/06/10H	3x07H	TS2 output ON time	Set value
20/50H	03/06/10H	3x08H	EV3 alarm value	Set value
20/50H	03/06/10H	3x09H	EV3 high limit alarm value	Set value
20/50H	03/06/10H	3x0AH	TS3 output OFF time	Set value
20/50H	03/06/10H	3x0BH	TS3 output ON time	Set value

Data item:

16³ digit: Event setting mode item (3 fixed)

16² digit: Pattern number [1 to A (10)]

16¹, 16⁰ digits: Data item identification number (00 to 0B)

Data:

Calculate TS□ output OFF time, TS□ output ON time, using the smaller time unit at 7018H (Step time unit), then convert it to hexadecimal numbers.

Setting range: 00:00 to 99:59 (0 to 5999) (0000H to 176FH)]

(e.g.) • 1 hour 30 minutes → 90 minutes → 005AH

• 15 minutes 30 seconds → 930 seconds → 03A2H

(3) Control Parameter Setting Mode Item

Shinko Command Type	Modbus Function Code	Data Item		Data
20/50H	03/06/10H	4000H	AT Perform/Cancel (*1)	0000H: AT Cancel 0001H: AT Perform
20/50H	03/06/10H	4001H	PID block number	0001H: Block 1 0002H: Block 2 0003H: Block 3 0004H: Block 4 0005H: Block 5 0006H: Block 6 0007H: Block 7 0008H: Block 8 0009H: Block 9 000AH: Block 10
20/50H	03/06/10H	4002H	OUT1 proportional cycle	Set value: 0 to 120 (00H to 78H) 0.5 seconds when set to 0.
20/50H	03/06/10H	4003H	OUT1 ON/OFF hysteresis	Set value, Decimal point ignored
20/50H	03/06/10H	4004H	OUT1 high limit	Set value
20/50H	03/06/10H	4005H	OUT1 low limit	Set value
20/50H	03/06/10H	4006H	OUT1 rate-of-change	Set value
20/50H	03/06/10H	4007H	OUT2 cooling method	0000H: Air cooling 0001H: Oil cooling 0002H: Water cooling
20/50H	03/06/10H	4008H	OUT2 proportional cycle	Set value: 0 to 120 (00H to 78H) 0.5 seconds when set to 0.
20/50H	03/06/10H	4009H	OUT2 ON/OFF hysteresis	Set value, Decimal point ignored
20/50H	03/06/10H	400AH	OUT2 high limit	Set value
20/50H	03/06/10H	400BH	OUT2 low limit	Set value
20/50H	03/06/10H	400CH	Overlap/Dead band	Set value, Decimal point ignored
20/50H	03/06/10H	400DH	Direct/Reverse action	0000H: Reverse action 0001H: Direct action
20/50H	03/06/10H	400EH	Heater burnout alarm 1 value	Set value, Decimal point ignored
20/50H	03/06/10H	400FH	Heater burnout alarm 2 value	Set value, Decimal point ignored
20/50H	03/06/10H	4010H	Loop break alarm time	Set value
20/50H	03/06/10H	4011H	Loop break alarm span	Set value, Decimal point ignored
20/50H	03/06/10H	4x12H	OUT1 proportional band	Set value, Decimal point ignored
20/50H	03/06/10H	4x13H	Integral time	Set value
20/50H	03/06/10H	4x14H	Derivative time	Set value
20/50H	03/06/10H	4x15H	ARW	Set value
20/50H	03/06/10H	4x16H	OUT2 proportional band	Set value, Decimal point ignored

Data item:

16³ digit: Control parameter setting mode item (4 fixed)

16² digit: PID block number [1 to A (10)] (OUT1 proportional band, Integral time, Derivative time, ARW, OUT2 proportional band)

16¹, 16⁰ digits: Data item identification number (00 to 16)

(4) Wait Parameter Setting Mode Item

Shinko Command Type	Modbus Function Code	Data Item		Data
20/50H	03/06/10H	5x00H	Wait value	Set value, Decimal point ignored
20/50H	03/06/10H	5x01H	Step 1 Wait function Enabled/Disabled	0000H: Disabled 0001H: Enabled
20/50H	03/06/10H	5x02H	Step 2 Wait function Enabled/Disabled	0000H: Disabled 0001H: Enabled
20/50H	03/06/10H	5x03H	Step 3 Wait function Enabled/Disabled	0000H: Disabled 0001H: Enabled
20/50H	03/06/10H	5x04H	Step 4 Wait function Enabled/Disabled	0000H: Disabled 0001H: Enabled
20/50H	03/06/10H	5x05H	Step 5 Wait function Enabled/Disabled	0000H: Disabled 0001H: Enabled
20/50H	03/06/10H	5x06H	Step 6 Wait function Enabled/Disabled	0000H: Disabled 0001H: Enabled
20/50H	03/06/10H	5x07H	Step 7 Wait function Enabled/Disabled	0000H: Disabled 0001H: Enabled
20/50H	03/06/10H	5x08H	Step 8 Wait function Enabled/Disabled	0000H: Disabled 0001H: Enabled
20/50H	03/06/10H	5x09H	Step 9 Wait function Enabled/Disabled	0000H: Disabled 0001H: Enabled
20/50H	03/06/10H	5x0AH	Step 10 Wait function Enabled/Disabled	0000H: Disabled 0001H: Enabled

Data item:

16³ digit: Wait parameter setting mode item (5 fixed)

16² digit: Pattern number [1 to A (10)]

16¹, 16⁰ digits: Data item identification number (00 to 0A)

(5) Engineering Setting Mode 1 Item

Shinko Command Type	Modbus Function Code	Data Item		Data
20/50H	03/06/10H	6000H	Set value lock	0000H: Unlock 0001H: Lock 1 0002H: Lock 2 0003H: Lock 3 0004H: Lock 4 0005H: Lock 5
20/50H	03/06/10H	6001H	Changeable in Set value lock	0000H: Step SV+ Step time changeable 0001H: Step SV+ Step time+ EV <input type="checkbox"/> alarm value changeable
20/50H	03/06/10H	6002H	Sensor correction coefficient	Set value, Decimal point ignored
20/50H	03/06/10H	6003H	Sensor correction	Set value, Decimal point ignored
20/50H	03/06/10H	6004H	PV filter time constant	Set value, Decimal point ignored
20/50H	03/06/10H	6005H	Response delay time	Set value
20/50H	03/06/10H	6006H	SVTC bias	Set value, Decimal point ignored

Data item:

16³ digit: Engineering setting mode 1 item (6 fixed)

16² digit: Reserved (0 fixed)

16¹, 16⁰ digits: Data item identification number (00 to 06)

(6) Engineering Setting Mode 2 Item

Shinko Command Type	Modbus Function Code	Data Item		Data
20/50H	03/06/10H	7000H	Input type	0000H: K -200 - 1370 °C 0001H: K -200.0 - 400.0 °C 0002H: J -200 - 1000 °C 0003H: R 0 - 1760 °C 0004H: S 0 - 1760 °C 0005H: B 0 - 1820 °C 0006H: E -200 - 800 °C 0007H: T -200.0 - 400.0 °C 0008H: N -200 - 1300 °C 0009H: PL-II 0 - 1390 °C 000AH: C(W/Re5-26) 0 - 2315 °C 000BH: Pt100 -200.0 - 850.0 °C 000CH: JPt100 -200.0 - 500.0 °C 000DH: Pt100 -200 - 850 °C 000EH: JPt100 -200 - 500 °C 000FH: K -328 - 2498 °F 0010H: K -328.0 - 752.0 °F 0011H: J -328 - 1832 °F 0012H: R 32 - 3200 °F 0013H: S 32 - 3200 °F 0014H: B 32 - 3308 °F 0015H: E -328 - 1472 °F 0016H: T -328.0 - 752.0 °F 0017H: N -328 - 2372 °F 0018H: PL-II 32 - 2534 °F 0019H: C(W/Re5-26) 32 - 4199 °F 001AH: Pt100 -328.0 - 1562.0 °F 001BH: JPt100 -328.0 - 932.0 °F 001CH: Pt100 -328 - 1562 °F 001DH: JPt100 -328 - 932 °F 001EH: 4 - 20 mA -2000 - 10000 001FH: 0 - 20 mA -2000 - 10000 0020H: 0 - 1 V -2000 - 10000 0021H: 0 - 5 V -2000 - 10000 0022H: 1 - 5 V -2000 - 10000 0023H: 0 - 10 V -2000 - 10000
20/50H	03/06/10H	7001H	Scaling high limit	Set value, Decimal point ignored
20/50H	03/06/10H	7002H	Scaling low limit	Set value, Decimal point ignored
20/50H	03/06/10H	7003H	Decimal point place	0000H: No decimal point 0001H: 1 digit after decimal point 0002H: 2 digits after decimal point 0003H: 3 digits after decimal point

Shinko Command Type	Modbus Function Code	Data Item		Data
20/50H	03/06/10H	7004H	Event output EV1 allocation (*2)	0000H: No event 0001H: High limit alarm 0002H: Low limit alarm 0003H: High/Low limits alarm 0004H: High/Low limits independent alarm 0005H: High/Low limit range alarm 0006H: High/Low limit range independent alarm 0007H: Process high alarm 0008H: Process low alarm 0009H: High limit with standby alarm 000AH: Low limit with standby alarm 000BH: High/Low limits with standby alarm 000CH: High/Low limits with standby independent alarm 000DH: Heater burnout alarm output 000EH: Loop break alarm output 000FH: Time signal output 0010H: Output during AT 0011H: Pattern end output 0012H: Output by communication command (8004H) 0013H: RUN output
20/50H	03/06/10H	7005H	EV1 alarm value 0 Enabled/Disabled (*2)	0000H: Disabled 0001H: Enabled
20/50H	03/06/10H	7006H	EV1 alarm hysteresis (*2)	Set value, Decimal point ignored
20/50H	03/06/10H	7007H	EV1 alarm delay time (*2)	Set value
20/50H	03/06/10H	7008H	EV1 alarm Energized/De-energized (*2)	0000H: Energized 0001H: De-energized
20/50H	03/06/10H	7009H	Event output EV2 allocation (*2)	0000H: No event 0001H: High limit alarm 0002H: Low limit alarm 0003H: High/Low limits alarm 0004H: High/Low limits independent alarm 0005H: High/Low limit range alarm 0006H: High/Low limit range independent alarm 0007H: Process high alarm 0008H: Process low alarm 0009H: High limit with standby alarm 000AH: Low limit with standby alarm 000BH: High/Low limits with standby alarm 000CH: High/Low limits with standby independent alarm 000DH: Heater burnout alarm output 000EH: Loop break alarm output 000FH: Time signal output 0010H: Output during AT 0011H: Pattern end output 0012H: Output by communication command (8004H) 0013H: RUN output 0014H: Heating/Cooling control output

Shinko Command Type	Modbus Function Code	Data Item		Data
20/50H	03/06/10H	700AH	EV2 alarm value 0 Enabled/Disabled (*2)	0000H: Disabled 0001H: Enabled
20/50H	03/06/10H	700BH	EV2 alarm hysteresis (*2)	Set value, Decimal point ignored
20/50H	03/06/10H	700CH	EV2 alarm delay time (*2)	Set value
20/50H	03/06/10H	700DH	EV2 alarm Energized/De-energized (*2)	0000H: Energized 0001H: De-energized
20/50H	03/06/10H	700EH	Event output EV3 allocation (*2)	0000H: No event 0001H: High limit alarm 0002H: Low limit alarm 0003H: High/Low limits alarm 0004H: High/Low limits independent alarm 0005H: High/Low limit range alarm 0006H: High/Low limit range independent alarm 0007H: Process high alarm 0008H: Process low alarm 0009H: High limit with standby alarm 000AH: Low limit with standby alarm 000BH: High/Low limits with standby alarm 000CH: High/Low limits with standby independent alarm 000DH: Heater burnout alarm output 000EH: Loop break alarm output 000FH: Time signal output 0010H: Output during AT 0011H: Pattern end output 0012H: Output by communication command (8004H) 0013H: RUN output
20/50H	03/06/10H	700FH	EV3 alarm value 0 Enabled/Disabled (*2)	0000H: Disabled 0001H: Enabled
20/50H	03/06/10H	7010H	EV3 alarm hysteresis (*2)	Set value, Decimal point ignored
20/50H	03/06/10H	7011H	EV3 alarm delay time (*2)	Set value
20/50H	03/06/10H	7012H	EV3 alarm Energized/De-energized (*2)	0000H: Energized 0001H: De-energized
20/50H	03/06/10H	7013H	Event input DI1 allocation	0000H: No event 0001H: Pattern number selection function 0002H: Direct/Reverse action 0003H: Program control RUN/STOP 0004H: Program control Holding/Not holding 0005H: Program control Advance function

Shinko Command Type	Modbus Function Code	Data Item		Data
20/50H	03/06/10H	7014H	Event input DI2 allocation	0000H: No event 0001H: Pattern number selection function 0002H: Direct/Reverse action 0003H: Program control RUN/STOP 0004H: Program control Holding/Not holding 0005H: Program control Advance function
20/50H	03/06/10H	7015H	Transmission output (*3)	0000H: PV transmission 0001H: SV transmission 0002H: MV transmission
20/50H	03/06/10H	7016H	Transmission output high limit(*3)	Set value, Decimal point ignored
20/50H	03/06/10H	7017H	Transmission output low limit(*3)	Set value, Decimal point ignored
20/50H	03/06/10H	7018H	Step time unit	0000H: Hours : Minutes 0001H: Minutes : Seconds
20/50H	03/06/10H	7019H	Power restore action	0000H: Stops after power is restored. 0001H: Continues (resumes) after power is restored. 0002H: Suspends (on hold) after power is restored.
20/50H	03/06/10H	701AH	Step SV when program control starts	Set value, Decimal point ignored
20/50H	03/06/10H	701BH	Program control start type	0000H: PV start 0001H: PVR start 0002H: SV start
20/50H	03/06/10H	701CH	Pattern end output time	Set value
20/50H	03/06/10H	701DH	AT bias	Set value, Decimal point ignored
20/50H	03/06/10H	701EH	Output status when input errors occur	0000H: Output OFF 0001H: Output ON
20/50H	03/06/10H	701FH	Indication time	Set value
20/50H	03/06/10H	7020H	Error indication	0000H: Disabled 0001H: Enabled

Data item:

16³ digit: Engineering setting mode 2 item (7 fixed)

16² digit: Reserved (0 fixed)

16¹, 16⁰ digits: Data item identification number (00 to 20)

Data:

Calculate Indication time, using the time unit second, then convert it to hexadecimal numbers.

Setting range: 00:00 to 60:00 (0 to 3600) (0000H to 0E10H)]

(e.g.) • 1 minute 00 seconds → 60 seconds → 003CH

• 15 minutes 30 seconds → 930 seconds → 03A2H

7.1.2 Operation Related Item Read/Write Command

Shinko Command Type	Modbus Function Code	Data Item		Data
20/50H	03/06/10H	8000H	Pattern number for operation ^(*4)	0001H: Pattern 1 for operation 0002H: Pattern 2 for operation 0003H: Pattern 3 for operation 0004H: Pattern 4 for operation 0005H: Pattern 5 for operation 0006H: Pattern 6 for operation 0007H: Pattern 7 for operation 0008H: Pattern 8 for operation 0009H: Pattern 9 for operation 000AH: Pattern 10 for operation
50H	06H/10H	8001H	Program control RUN (Cancels HOLD) / STOP	0000H: Program control STOP 0001H: Program control RUN (Cancels HOLD)
50H	06H/10H	8002H	Program control HOLD ^(*5)	0001H: HOLD
50H	06H/10H	8003H	Program control ADVANCE ^(*5)	0001H: ADVANCE
50H	06H/10H	8004H	Output by communication command	2 ⁰ digit: EV1 output 0: OFF 1: ON 2 ¹ digit: EV2 output 0: OFF 1: ON 2 ² digit: EV3 output 0: OFF 1: ON
50H	06H/10H	8005H	Key operation change flag clearing	0001H: Clear key operation change flag

Data item:

16³ digit: Operation related item (8 fixed)

16² digit: Reserved (0 fixed)

16¹, 16⁰ digits: Data item identification number (00 to 05)

7.1.3 Read Only Command

Shinko Command Type	Modbus Function Code	Data Item		Data
20H	03H	9000H	PV	Current PV (Decimal point ignored)
20H	03H	9001H	OUT1 MV	Current OUT1 MV (Decimal point ignored)
20H	03H	9002H	OUT2 MV	Current OUT2 MV (Decimal point ignored)
20H	03H	9003H	Current step SV	Current step SV (Decimal point ignored)
20H	03H	9004H	Current step remaining time	Current step remaining time
20H	03H	9005H	Current running pattern and step	16 ⁰ digit: Running pattern 16 ¹ digit: Running step 16 ² to 16 ³ digits: Reserved (0) If program control has stopped, the pattern number at the time of stop will be returned. For step number, 0 (zero) will be returned.
20H	03H	9006H	Current number of repetitions	Current number of repetitions
20H	03H	9007H	Pattern selected by Event input	Selected pattern
20H	03H	9008H	CT1 current value	CT1 current value (Decimal point ignored)
20H	03H	9009H	CT2 current value	CT2 current value (Decimal point ignored)
20H	03H	900AH	Status flag	2 ⁰ digit: OUT1 0: OFF 1: ON 2 ¹ digit: OUT2 0: OFF 1: ON 2 ² digit: Event output EV1 0: OFF 1: ON 2 ³ digit: Event output EV2 0: OFF 1: ON 2 ⁴ digit: Event output EV3 0: OFF 1: ON 2 ⁵ digit: Undefined (0) 2 ⁶ digit: Loop break alarm output 0: OFF 1: ON 2 ⁷ digit: Overscale 0: OFF 1: ON 2 ⁸ digit: Underscale 0: OFF 1: ON 2 ⁹ digit: Heater burnout alarm output 0: OFF 1: ON 2 ¹⁰ to 2 ¹⁴ digits: Undefined (0) 2 ¹⁵ digit: Change in key operation 0: No 1: Yes

Shinko Command Type	Modbus Function Code	Data Item		Data
20H	03H	900BH	Current unit status	2 ⁰ digit: Control mode 1: Program control (Fixed) 2 ¹ digit: AT Perform/Cancel 0: AT Cancel 1: AT Perform 2 ² digit: Program control RUN/STOP 0: Program control STOP 1: Program control RUN 2 ³ digit: Program control (HOLD) 0: OFF 1: HOLD 2 ⁴ digit: Program control (WAIT) 0: OFF 1: WAIT 2 ⁵ digit: Pattern end output 0: OFF 1: ON 2 ⁶ to 2 ¹⁵ digits: Undefined (0)
20H	03H	900CH	Error status flag 1	2 ⁰ digit: Error 01 0: OFF 1: ON 2 ¹ digit: Error 02 0: OFF 1: ON 2 ² digit: Reserved 2 ³ digit: Reserved 2 ⁴ digit: Error 05 0: OFF 1: ON 2 ⁵ digit: Error 06 0: OFF 1: ON 2 ⁶ digit: Error 07 0: OFF 1: ON 2 ⁷ digit: Reserved 2 ⁸ digit: Reserved 2 ⁹ digit: Error 10 0: OFF 1: ON 2 ¹⁰ to 2 ¹⁵ digits: Reserved
20H	03H	900DH	Error status flag 2	2 ⁰ to 2 ² digits: Reserved 2 ³ digit: Error 20 0: OFF 1: ON 2 ⁴ to 2 ¹⁵ digits: Reserved

Data item:

- 16³ digit: Operation related item (9 fixed)
- 16² digit: Reserved (0 fixed)
- 16¹, 16⁰ digits: Data item identification number (00 to 0D)

Read/Write of Multiple Pieces of Data

- For non-existent data address, if multiple pieces of data are read, acknowledgement will be returned (but data is 0). If multiple pieces of data are written, acknowledgement will be returned, and data will be discarded.

(*1) If Write is executed in Program control standby mode, Error code 4 (34H, Shinko protocol) or Exception code 17 (11H, Modbus protocol) will be returned.

(*2) If Alarm type is changed in [Event output EV1/EV2/EV3 allocation], then the following will be cleared:

- EV1/EV2/EV3 alarm value 0 Enabled/Disabled, EV1/EV2/EV3 alarm hysteresis,
- EV1/EV2/EV3 alarm delay time, EV1/EV2/EV3 alarm Energized/De-energized

Alarm output status will also be initialized.

(*3) Transmission output high limit value and Transmission output low limit value will be cleared in the following cases.

- When transmission output type is changed in [Transmission output type].
- When PV transmission or SV transmission is selected in [Transmission output type], and input type is changed.

(*4) Available when Pattern number 1 is selected by Event input DI□, and during program control standby mode.

(*5) If Write is executed in Program control standby mode, Error code 4 (34H, Shinko protocol) or Exception code 17 (11H, Modbus protocol) will be returned.

7.2 PCD-33A Command

7.2.1 Read/Write Command

Shinko Command Type	Modbus Function Code	Data Item		Data
20/50H	03H/06H	0001H	Not used	
20/50H	03H/06H	0002H	Proportional band ^{(*)1}	Set value, Decimal point ignored
20/50H	03H/06H	0003H	Integral time ^{(*)1}	Set value
20/50H	03H/06H	0004H	Derivative time ^{(*)1}	Set value
20/50H	03H/06H	0005H	ARW ^{(*)1}	Set value
20/50H	03H/06H	0006H	Not used	
20/50H	03H/06H	0007H	Not used	
20/50H	03H/06H	0008H	Not used	
20/50H	03H/06H	0009H	Not used	
20/50H	03H/06H	000AH	Not used	
20/50H	03H/06H	000BH	Not used	
20/50H	03H/06H	000CH	Not used	
20/50H	03H/06H	000DH	Not used	
20/50H	03H/06H	000EH	AT Perform/Cancel ^{(*)2}	0000H: AT Cancel 0001H: AT Perform
20/50H	03H/06H	000FH	Event output EV1 allocation (A1 type) ^{(*)3} ^{(*)4}	0000H: No event 0001H: High limit alarm 0002H: Low limit alarm 0003H: High/Low limits alarm 0004H: High/Low limit range alarm 0005H: Process high alarm 0006H: Process low alarm 0007H: High limit with standby alarm 0008H: Low limit with standby alarm 0009H: High/Low limits with standby alarm
20/50H	03H/06H	0010H	Event output EV2 allocation (A2 type) ^{(*)3} ^{(*)4}	0000H: No event 0001H: High limit alarm 0002H: Low limit alarm 0003H: High/Low limits alarm 0004H: High/Low limit range alarm 0005H: Process high alarm 0006H: Process low alarm 0007H: High limit with standby alarm 0008H: Low limit with standby alarm 0009H: High/Low limits with standby alarm
20/50H	03H/06H	0011H	EV1 alarm (A1) hysteresis ^{(*)3}	Set value, Decimal point ignored
20/50H	03H/06H	0012H	EV2 alarm (A2) hysteresis ^{(*)3}	Set value, Decimal point ignored
20/50H	03H/06H	0013H	Not used	
20/50H	03H/06H	0014H	Not used	
20/50H	03H/06H	0015H	EV1 alarm (A1) delay time ^{(*)3}	Set value
20/50H	03H/06H	0016H	EV2 alarm (A2) delay time ^{(*)3}	Set value
20/50H	03H/06H	0017H	Not used	

Shinko Command Type	Modbus Function Code	Data Item		Data
20/50H	03H/06H	0018H	Not used	
20/50H	03H/06H	0019H	Not used	
20/50H	03H/06H	001AH	Not used	
20/50H	03H/06H	001BH	OUT proportional cycle	Set value
20/50H	03H/06H	001CH	OUT high limit	Set value
20/50H	03H/06H	001DH	OUT low limit	Set value
20/50H	03H/06H	001EH	OUT ON/OFF hysteresis	Set value, Decimal point ignored
20/50H	03H/06H	001FH	Not used	
20/50H	03H/06H	0020H	Not used	
20/50H	03H/06H	0021H	Not used	
20/50H	03H/06H	0022H	Not used	
20/50H	03H/06H	0023H	Not used	
20/50H	03H/06H	0024H	Not used	
20/50H	03H/06H	0025H	Not used	
20/50H	03H/06H	0026H	Not used	
20/50H	03H/06H	0027H	SV high limit (*1)	Set value, Decimal point ignored
20/50H	03H/06H	0028H	SV low limit (*1)	Set value, Decimal point ignored
20/50H	03H/06H	0029H	Not used	
20/50H	03H/06H	002AH	Not used	
20/50H	03H/06H	002BH	Not used	
20/50H	03H/06H	002CH	Scaling high limit	Set value, Decimal point ignored
20/50H	03H/06H	002DH	Scaling low limit	Set value, Decimal point ignored
20/50H	03H/06H	002EH	Decimal point place	0000H: No decimal point 0001H: 1 digit after decimal point 0002H: 2 digits after decimal point 0003H: 3 digits after decimal point
20/50H	03H/06H	002FH	Sensor correction	Set value, Decimal point ignored
20/50H	03H/06H	0030H	PV filter time constant	Set value, Decimal point ignored
20/50H	03H/06H	0031H	Set value lock (*4)	0000H: Unlock 0001H: Lock (Same as Lock 1)
20/50H	03H/06H	0032H	Step SV when program control starts	Set value, Decimal point ignored
20/50H	03H/06H	0033H	Program control start type (*4)	0000H: PV start 0001H: SV start
20/50H	03H/06H	0034H	Not used	
20/50H	03H/06H	0035H	Step time unit	0000H: Hours : Minutes 0001H: Minutes : Seconds
20/50H	03H/06H	0036H	Not used	
20/50H	03H/06H	0037H	Not used	
20/50H	03H/06H	0038H	Pattern end output time	Set value
20/50H	03H/06H	0039H	Not used	
20/50H	03H/06H	003AH	Not used	

Shinko Command Type	Modbus Function Code	Data Item		Data
20/50H	03H/06H	003BH	Event output EV3 allocation (EVT function) (*4)	0000H: Time signal output 0001H: Pattern end output 0002H: RUN output
20/50H	03H/06H	003CH	Not used	
20/50H	03H/06H	003DH	Not used	
20/50H	03H/06H	003EH	Not used	
20/50H	03H/06H	003FH	Pattern number for operation (*4)	0001H: Pattern 1 for operation 0002H: Pattern 2 for operation 0003H: Pattern 3 for operation 0004H: Pattern 4 for operation 0005H: Pattern 5 for operation 0006H: Pattern 6 for operation 0007H: Pattern 7 for operation 0008H: Pattern 8 for operation 0009H: Pattern 9 for operation
20/50H	03H/06H	0040H	Not used	
20/50H	03H/06H	0041H	Not used	
50H	06H	0042H	Program control RUN (Cancels HOLD) / STOP	0000H: Program control STOP 0001H: Program control RUN (Cancels HOLD)
50H	06H	0043H	Program control ADVANCE (*5)	0001H: ADVANCE

Shinko Command Type	Modbus Function Code	Data Item		Data
20/50H	03H/06H	0044H	Input type	0000H: K -200 - 1370 °C 0001H: K -200.0 - 400.0 °C 0002H: J -200 - 1000 °C 0003H: R 0 - 1760 °C 0004H: S 0 - 1760 °C 0005H: B 0 - 1820 °C 0006H: E -200 - 800 °C 0007H: T -200.0 - 400.0 °C 0008H: N -200 - 1300 °C 0009H: PL-II 0 - 1390 °C 000AH: C(W/Re5-26) 0 - 2315 °C 000BH: Pt100 -200.0 - 850.0 °C 000CH: JPt100 -200.0 - 500.0 °C 000DH: Pt100 -200 - 850 °C 000EH: JPt100 -200 - 500 °C 000FH: K -328 - 2498 °F 0010H: K -328.0 - 752.0 °F 0011H: J -328 - 1832 °F 0012H: R 32 - 3200 °F 0013H: S 32 - 3200 °F 0014H: B 32 - 3308 °F 0015H: E -328 - 1472 °F 0016H: T -328.0 - 752.0 °F 0017H: N -328 - 2372 °F 0018H: PL-II 32 - 2534 °F 0019H: C(W/RE5-26) 32 - 4199 °F 001AH: Pt100 -328.0 - 1562.0 °F 001BH: JPt100 -328.0 - 932.0 °F 001CH: Pt100 -328 - 1562 °F 001DH: JPt100 -328 - 932 °F 001EH: 4 - 20 mA -2000 - 10000 001FH: 0 - 20 mA -2000 - 10000 0020H: 0 - 1 V -2000 - 10000 0021H: 0 - 5 V -2000 - 10000 0022H: 1 - 5 V -2000 - 10000 0023H: 0 - 10 V -2000 - 10000
20/50H	03H/06H	0045H	Direct/Reverse action	0000H: Reverse action 0001H: Direct action
20/50H	03H/06H	0046H	Not used	
20/50H	03H/06H	0047H	Not used	
20/50H	03H/06H	0048H	EV1 alarm (A1) Energized/De-energized ^(*3)	0000H: Energized 0001H: De-energized
20/50H	03H/06H	0049H	EV2 alarm (A2) Energized/De-energized ^(*3)	0000H: Energized 0001H: De-energized
50H	06H	0070H	Key operation change flag clearing	0001H: Clear all
20/50H	03H/06H	1xx0H	Step SV ^(*6)	Set value, Decimal point ignored
20/50H	03H/06H	1xx1H	Step time ^{(*6) (*7)}	Set value (Minutes or seconds)
20/50H	03H/06H	1xx2H	Wait Enabled/Disabled ^(*6)	0000H: Disabled 0001H: Enabled

Shinko Command Type	Modbus Function Code	Data Item		Data
20/50H	03H/06H	1x13H	Wait value ^(*)8)	Set value
20/50H	03H/06H	1x14H	EV1 alarm (A1) value ^(*)8)	Set value
20/50H	03H/06H	1x15H	EV2 alarm (A2) value ^(*)8)	Set value
20/50H	03H/06H	1x16H	TS1 (Time signal) output OFF time ^(*)7) ^(*)8)	Set value (Minutes or Seconds)
20/50H	03H/06H	1x17H	TS1 (Time signal) output ON time ^(*)7) ^(*)8)	Set value (Minutes or Seconds)
20/50H	03H/06H	1xx8H	Step PID block number ^(*)6)	0001H: Block 1 0002H: Block 2 0003H: Block 3 0004H: Block 4 0005H: Block 5 0006H: Block 6 0007H: Block 7 0008H: Block 8 0009H: Block 9 000AH: Block 10
20/50H	03H/06H	1x19H	Pattern link ^(*)8)	0000H: Pattern link Disabled 0001H: Pattern link Enabled
20/50H	03H/06H	1x1AH	Proportional band ^(*)9)	Set value, Decimal point ignored
20/50H	03H/06H	1x1BH	Integral time ^(*)9)	Set value
20/50H	03H/06H	1x1CH	Derivative time ^(*)9)	Set value
20/50H	03H/06H	1x1DH	ARW ^(*)9)	Set value

7.2.2 Read Only Command

Shinko Command Type	Modbus Function Code	Data Item		Data
20H	03H	0080H	PV	Current PV
20H	03H	0081H	OUT MV	Current OUT1 MV
20H	03H	0082H	Not used	
20H	03H	0083H	Current step SV	Current step SV
20H	03H	0084H	Current control step remaining time	Current step remaining time
20H	03H	0085H	Current running pattern and step	16 ⁰ digit: Running pattern 16 ¹ digit: Running step 16 ² , 16 ³ digits: Not used (always 0)
20H	03H	0086H	Status flag 1	2 ⁰ digit: OUT 0: OFF 1: ON (For current output: Not fixed) 2 ¹ digit: Not used (always 0) 2 ² digit: Event output EV1 (A1 output) 0: OFF 1: ON 2 ³ digit: Event output EV2 (A2 output) 0: OFF 1: ON 2 ⁴ digit: Event output EV3 (EVT output) 0: OFF 1: ON 2 ⁵ , 2 ⁶ digits: Not used (always 0) 2 ⁷ digit: Overscale 0: OFF 1: ON 2 ⁸ digit: Underscale 0: OFF 1: ON 2 ⁹ digit: Program control RUN/STOP 0: Program control STOP 1: Program control RUN 2 ¹⁰ digit: Program control (WAIT) 0: OFF 1: WAIT 2 ¹¹ digit: AT Perform/Cancel 0: AT Cancel 1: AT Perform 2 ¹² digit: Program control (HOLD) 0: OFF 1: HOLD 2 ¹³ , 2 ¹⁴ digits: Not used (always 0) 2 ¹⁵ digit: Change in key operation 0: No 1: Yes
20H	03H	00A2H	Not used	

(*1) If Read is executed, acknowledgement will be returned (but data is 0).

If Write is executed, acknowledgement will be returned, and data will be discarded

(*2) If Write is executed in program control standby mode, Error code 4 (34H, Shinko protocol) or Exception code 17 (11H, Modbus protocol) will be returned.

(*3) If an alarm type is changed in [Event output EV1/EV2 allocation], the following will be cleared:

EV1/EV2 alarm hysteresis, EV1/EV2 alarm delay time. EV1/EV2 alarm Energized/De-energized
Alarm output status will also be initialized.

(*4) Read/Write range of setting value are different from those of key operation.

(*5) If Write is executed in program control standby mode, Error code 4 (34H, Shinko protocol) or Exception code 17 (11H, Modbus protocol) will be returned.

(*6) 16¹ digit: Step number 1 to A (10)

16² digit: Pattern number 1 to A (10)

(*7) Calculate Step time, TS□ output OFF time, TS□ output ON time, using the smaller time unit at 0035H (Step time unit), then convert it to hexadecimal numbers.

Setting range: 00:00 to 99:59 (0 to 5999) (0000H to 176FH)]

(e.g.) 1 hour 30 minutes → 90 minutes → 005AH

15 minutes 30 seconds → 930 seconds → 03A2H

□□□□ (FFFFH): The step time is held, and Fixed value control is performed using the step SV.

(*8) 16² digit: Pattern number 1 to A (10).

(*9) 16² digit: PID block number 1 to A (10).

7.3 Data

7.3.1 Notes about Write/Read Command

- The data (set value, decimal) is converted to a hexadecimal number. Negative numbers are represented in 2's complement.
- When connecting multiple slaves, the address (instrument number) must not be duplicated.
- Do not use undefined Data items. If they are used, negative acknowledgement will be returned or a random value will be written or read, resulting in malfunction.
- Modbus protocol uses Holding Register addresses. The Holding Register addresses are created as follows. A Shinko command data item is converted to decimal number, and the offset of 40001 is added. The result is the Holding Register address.
Using Pattern 1, Step 1, Step SV (2100H) as an example: Data item in the sending message is 2100H, however, Modbus protocol Holding Register address is 42101 (2100+40001).

7.3.2 Write Command

- Up to 1,000,000 (one million) entries can be stored in non-volatile IC memory. If the number of settings exceeds the limit, the data will not be saved. So, do not change the set values frequently via software communication. (If a value set via software communication is the same as the value before the setting, the value will not be written in non-volatile IC memory.)
- Setting range of each item is the same as that of keypad operation.
- When data (set value) has a decimal point, a whole number (hexadecimal) without a decimal point is used.
- If any action is changed at 7004H, 7009H, or at 000FH, 0010H (Event output EV1/EV2 allocation), the following values will revert to the factory default value:
EV1 alarm hysteresis (7006H, 0011H), EV2 alarm hysteresis (700BH, 0012H)
For the items to be initialized, refer to Section "7.7 Items to Be Initialized by Changing Settings" (pp.48, 49).
- Writings via software communication are possible while in Set value lock status.
- Even if options are not ordered, Writing or reading via software communication will be possible. However, their command contents will not function.
- The Instrument Numbers and Communication Speed of the slave cannot be set by software communication. They can only be set via the keypad.
- When Write is executed using the Global address [95 (7FH), Shinko protocol] command or Broadcast address [0 (00H) Modbus protocol] command, the command is sent to all the connected slaves. However, a response is not returned.

7.3.3 Read Command

- When the data (set value) has a decimal point, a whole number (hexadecimal) without a decimal point is used for a response.

7.4 Negative Acknowledgement

7.4.1 Error code 1 (31H, Shinko protocol) or Exception code 2 (02H, Modbus protocol)

The slave will return Error code 1 (31H, Shinko protocol) or Exception code 2 (02H, Modbus protocol) in the following case.

- When non-existent data item is read or written.

7.4.2 Error code 3 (33H, Shinko protocol) or Exception code 3 (03H, Modbus protocol)

The slave will return Error code 3 (33H, Shinko protocol) or Exception code 3 (03H, Modbus protocol) in the following case.

- When a value out of the setting range is written.

7.4.3 Error code 4 (34H, Shinko protocol) or Exception code 17 (11H, Modbus protocol)

The slave will return Error code 4 (34H, Shinko protocol) or Exception code 17 (11H, Modbus protocol) in the following cases.

- During ON/OFF control action, if 0001H (AT Perform) is written at 4000H or 000EH (AT Perform/Cancel).
- While AT is performing during Fixed value control, if 0001H (AT Perform) is written at 4000H or 000EH (AT Perform/Cancel).
- While AT is performing during Program control, if 0001H (AT Perform) is written at 4000H or 000EH (AT Perform/Cancel).

7.4.4 Error code 5 (35H, Shinko protocol) or Exception code 18 (12H, Modbus protocol)

The slave will return Error code 5 (35H, Shinko protocol) or Exception code 18 (12H, Modbus protocol) in the following case.

- During setting mode by keypad operation

7.5 Notes on Programming Monitoring Software

7.5.1 How to Speed up the Scan Time

When monitoring multiple units of the controller, set the program so that the requisite minimum pieces of data such as Data item 9000H/0080H (PV), 9001H or 0081H (OUT1 MV), 900AH/0086H (Status flag 1) can be read.

For other data, set the program so that they can be read only when their set value has changed.

This will speed up the scan time.

7.5.2 How to Read the Set Value Changes Made by Front Keypad Operation

If any set value is changed by the keypad operation, the controller sets the [900AH or 0086H (Status flag 1) B15: Change in key operation] to 1 (Yes).

There are 2 methods of reading the set value changes made by front keypad.

(1) Reading method 1

- ① On the monitoring software side, check that [900AH or 0086H (Status flag 1) B15: Change in key operation] has been set to 1 (Yes), then read all set values.
- ② Clear [900AH or 0086H (Status flag 1) B15: Change in key operation], by writing Data item 8005H or 0070H (Key operation change flag clearing) to 0001H (Clear key operation change flag).
If 8005H or 0070H (Key operation change flag clearing) is written to 0001H (Clear key operation change flag) during the setting mode of the controller, Error code 5 (35H, Shinko protocol) or Exception Code 18 (12H, Modbus protocol) will be returned as a negative acknowledgement. And [900AH or 0086H (Status flag 1) B15: Change in key operation] cannot be cleared.
Set a program so that all set values can be read when a negative acknowledgement is returned.
- ③ Read all set values again after acknowledgement is returned.

(2) Reading method 2

- ① On the monitoring software side, check that [900AH or 0086H (Status flag 1) B15: Change in key operation] has been set to 1 (Yes), then write the 8005H or 0070H (Key operation change flag clearing) to 0001H (Clear key operation change flag).
- ② Set the program depending on the acknowledgement or negative acknowledgement as follows.
When acknowledgement is returned;
 Consider it as settings completed, and read all set values.
When Error code 5 (35H, Shinko protocol) or Exception code 18 (12H, Modbus protocol) is returned as a negative acknowledgement;
 Consider it as still in setting mode, and read the requisite minimum pieces of data such as 9000H/0080H (PV), 9001H/0081H (OUT1 MV), 900AH/0086H (Status flag 1), then return to Step ①.

Thus, programs which do not affect the scan time can be created using the methods described above, even if set values on the monitoring software will not be updated until settings are complete.

7.5.3 How to Read PID Parameters after AT Finishes

While AT is performing, this controller sets [900BH (Current unit status) B1: AT Perform/Cancel] or [0086H (Status flag 1) B11: AT Perform/Cancel] to 1 (AT Perform).

After AT is finished, PID parameters are updated.

On the monitoring software side, check that [900BH (Current unit status) B1: AT Perform/Cancel] or [0086H (Status flag 1) B11: AT Perform/Cancel] has been set to 0 (AT Cancel), then read parameters such as P, I, D, ARW.

7.5.4 Note When Sending All Set Values Simultaneously

- When changing alarm types at 7004H, 7009H or at 000FH, 0010H (Event output EV1/EV2 allocation), the following values will revert to factory default value:
 EV1 alarm hysteresis (7006H or 0011H), EV2 alarm hysteresis (700BH or 0012H)
First, send the selected alarm type, then send each item.
Refer to Section '7.7 Items to be Initialized by Changing Settings'. (pp. 48, 49)
- When changing input types at 7000H or 0044H (Input type), the following values will be initialized:
 Sensor correction, Scaling high limit, Scaling low limit, etc.
First, send the selected input type, then send other set values.

7.6 When Communicating with a PLC

To communicate with a PLC, use a Shinko PLC Interface Unit SIF-600.

No programming is needed for connection.

PLCs corresponding to the SIF-600, its manufacturer and host link units:

PLC Manufacturer	PLC Model, Series Name	Host Link Unit Model
Mitsubishi Electric Corp.	MELSEC Q, QnA series (*)	AJ71UC24, A1SJ71UC24-R2/R4/PRF A1SJ71C24-R2/R4/PRF, QJ71C24
	MELSEC FX series (*)	
Omron Corp.	SYSMAC CJ series	CS1W-SCU21-V1 CJ1W-SCU21, CJ1W-SCU41
Keyence Corp.	KV	KV-L20V
Yokogawa Electric Corp.	FA-M3	F3LC11-2N, F3LC11-1F, F3LC12-1F
Fuji Electric Co., Ltd.	MICREX-SX series	NP1L-RS1, NP1L-RS2, NP1L-RS3 NP1L-RS4

(*) Models with compatible QR/QW communication commands

7.7 Items to be Initialized by Changing Settings

7.7.1 Shinko Protocol/Modbus ASCII/Modbus RTU

If settings are changed, the following items will be initialized.

●: Initialized

X: Not initialized

Item to be initialized \ Setting item to be changed	Input type (7000H/0044H)	Event output EV1 allocation (7004H/000FH)	Event output EV2 allocation (7009H/0010H)	Event output EV3 allocation (700EH)	Transmission output (7015H)
Loop break alarm time	●	X	X	X	X
Loop break alarm span	●	X	X	X	X
Sensor correction coefficient	●	X	X	X	X
Sensor correction	●	X	X	X	X
SVTC bias	●	X	X	X	X
Scaling high limit	●	X	X	X	X
Scaling low limit	●	X	X	X	X
EV1 alarm value 0 Enabled/Disabled	X	●	X	X	X
EV1 alarm hysteresis	X	●	X	X	X
EV1 alarm delay time	X	●	X	X	X
EV1 alarm Energized/De-energized	X	●	X	X	X
EV2 alarm value 0 Enabled/Disabled	X	X	●	X	X
EV2 alarm hysteresis	X	X	●	X	X
EV2 alarm delay time	X	X	●	X	X
EV2 alarm Energized/De-energized	X	X	●	X	X
EV3 alarm value 0 Enabled/Disabled	X	X	X	●	X
EV3 alarm hysteresis	X	X	X	●	X
EV3 alarm delay time	X	X	X	●	X
EV3 alarm Energized/De-energized	X	X	X	●	X
Transmission output high limit (*)	●	X	X	X	●
Transmission output low limit (*)	●	X	X	X	●
Step SV when program control starts	●	X	X	X	X
AT bias	●	X	X	X	X

(*) When PV transmission or SV transmission is selected in [Transmission output type], and input type is changed, it will be initialized.

7.7.2 PCD-33A Command

For the PCD-33A command, the following items will be initialized when settings are changed.

●: Initialized

x: Not initialized

Item to be initialized \ Setting item to be changed	Input type (7000H/0044H)	Event output EV1 allocation (7004H/000FH)	Event output EV2 allocation (7009H/0010H)
Loop break alarm time	●	X	X
Loop break alarm span	●	X	X
Sensor correction coefficient	●	X	X
Sensor correction	●	X	X
SVTC bias	●	X	X
Scaling high limit	●	X	X
Scaling low limit	●	X	X
EV1 alarm value 0 Enabled/Disabled	X	●	X
EV1 alarm hysteresis	X	●	X
EV1 alarm delay time	X	●	X
EV1 alarm Energized/De-energized	X	●	X
EV2 alarm value 0 Enabled/Disabled	X	X	●
EV2 alarm hysteresis	X	X	●
EV2 alarm delay time	X	X	●
EV2 alarm Energized/De-energized	X	X	●
Transmission output high limit (*)	●	X	X
Transmission output low limit (*)	●	X	X
Step SV when program control starts	●	X	X
AT bias	●	X	X

(*) When PV transmission or SV transmission is selected in [Transmission output type], and input type is changed, it will be initialized.

8. SV Digital Transmission

By connecting to Shinko programmable controllers [PC-900 or PCD-33A with the SVTC (Set value digital transmission) option, PCA1, PCB1], digital SV via the SVTC command can be received from Shinko programmable controllers.

8.1 Wiring

For the PC-900, connect YA (-) to YA (-), YB (+) to YB (+), COM (PC-900) to SG (PCB1) terminal respectively. For the PCD-33A, PCA1 or PCB1, connect YA (-) to YA (-), YB (+) to YB (+), SG to SG terminal respectively.

Up to 31 units of the PCB1 can be connected.

The following shows a connection example of PCA1 and PCB1.

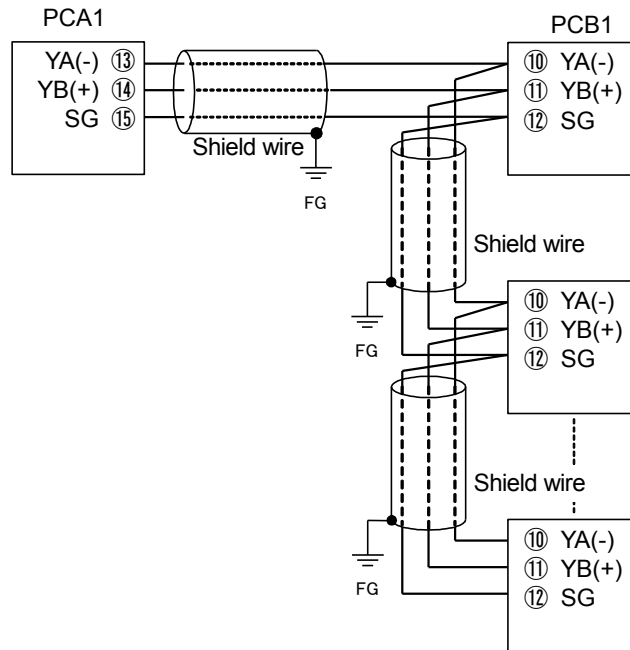

(Fig. 8.1-1)

8.2 Setting Method of Instruments

(1) Setting the PC-900, PCD-33A, PCA1, PCB1

For PC-900, PCD-33A, if the SVTC option is ordered, none of the settings are required.

PC-900: Check that 'Set value digital transmission (4bit)' is selected in [Communication mode, 274].

PCD-33A: Check that 'Set value digital transmission (4bit)' is selected in [Communication protocol, 274] in Auxiliary function setting mode 1.

PCA1, PCB1: Select 'SV digital transmission' in [Communication protocol].

(2) Setting the PCB1

Check the following items in Engineering mode 1.

Refer to Section '3. Setting Communication Parameters'. (p. 4)

- 'SV digital reception (Shinko protocol) has been selected in [Communication protocol].
- Communication speed of the PCB1 is equal to that of the PC-900, PCD-33A or PCA1 (9600 bps, 19200 bps or 38400 bps).

(3) Starting 'SV digital transmission'

Enter the program setting values on the PC-900, PCD-33A, PCA1 or PCB1.

If the program is executed by pressing the **RUN** Key, Step SV of the PC-900, PCD-33A, PCA1 or PCB1 will be sent to the PCB1.

During program Standby, 0 (zero) will be sent to the PCB1.

9. Specifications

Cable length	1.2 km (Max.), Cable resistance: Within 50 Ω (Terminators are not necessary, but if used, use 120 Ω or more on both sides.)			
Communication interface	EIA RS-485			
Communication method	Half-duplex communication			
Communication speed	9600, 19200, 38400 bps (Selectable by keypad)			
Synchronization method	Start-stop synchronization			
Code form	ASCII, binary			
Data bit/Parity	7, 8 / Even, Odd, No parity (Selectable by keypad)			
Stop bit	1, 2 (Selectable by keypad)			
Communication protocol	Shinko protocol, Modbus ASCII, Modbus RTU (Selectable by keypad)			
Data format				
	Communication Protocol	Shinko Protocol	Modbus ASCII	Modbus RTU
	Start bit	1	1	1
	Data bit	7 (8) Selectable	7 (8) Selectable	8
	Parity	Even (No parity, Odd) Selectable	Even (No parity, Odd) Selectable	No parity (Even, Odd) Selectable
	Stop bit	1 (2) Selectable	1 (2) Selectable	1 (2) Selectable
Number of connectable units	Max 31 units to 1 host computer			
Error correction	Command request repeat system			
Error detection	Parity, checksum (Shinko protocol), LRC (Modbus ASCII), CRC-16 (Modbus RTU)			
Digital external setting	Receives digital SV via the SVTC command by connecting to Shinko programmable controllers (PC-900/PCD-33A with the SVTC option, PCA1/PCB1 with SV digital transmission in [Communication protocol]).			

10. Troubleshooting

Check that power is being supplied to the master and slave that customers use. If communication failure still occurs, check the following.

Problem	Possible Cause	Solution
Communication failure	Communication cable is not securely connected, or is disconnected/defective.	Check the communication cable and connector.
	Incorrect wiring of the communication cable and/or connector	Check the communication cable and connector. Refer to Section '2. Wiring' (pp. 2, 3).
	Imperfect contact between the communication cable and the connector, or between the communication connector and instrument port	Check the communication cable and connector.
	Communication speed of the slave does not match that of the master.	Set the same communication speed on the master and the slave. Refer to Section '3. Setting Communication Parameters' (pp. 4, 5).
	The data bit, parity and stop bit of the master do not correspond to those of the slave.	Set the same data bit, parity and stop bit on the master and the slave. Refer to Section '3. Setting Communication Parameters' (pp. 4, 5).
	The instrument number (address) of the slave does not correspond to that of the command.	Check the instrument number (address) of the slave and the command. Refer to Section '3. Setting Communication Parameters' (pp. 4, 5).
	The instrument numbers (addresses) are duplicated in multiple slaves.	Check that each slave has a different instrument number (address). Refer to Section '3. Setting Communication Parameters' (pp. 4, 5).
	Make sure that the program is appropriate for the transmission timing.	Check the program. Refer to Section '4. Communication Procedure' (p.6).
Although communication is occurring, the response is negative acknowledgement.	A non-existent command code has been sent.	Check the command code.
	The Write command data exceeds the setting range of the slave.	Check the setting range of the slave.
	The controller cannot be written when functions such as AT are performing.	Check the slave status.
	The PCB1 is in front keypad operation setting mode.	Return the controller to RUN mode.

For all other malfunctions, please contact our main office or dealers.

SHINKO TECHNOS CO., LTD. OVERSEAS DIVISION

Head Office : 2-5-1, Senbahigashi, Minoo, Osaka, Japan

URL: <http://www.shinko-technos.co.jp/e/>

E-mail: overseas@shinko-technos.co.jp

Tel : +81-72-727-6100

Fax: +81-72-727-7006