

This manual contains instructions for communication functions of the PCA1.

Serial communication and Console communication cannot be used together.  
 When performing Serial communication, remove the USB communication cable (CMB-001) from the USB port of the PC and console connector of the PCA1.  
 When performing Console communication, it is not required to remove the Serial communication cables.  
 However, do not send a command from the master side.

# 1. System Configuration

## 1.1 When Using USB Communication Cable CMC-001-1 (sold separately)

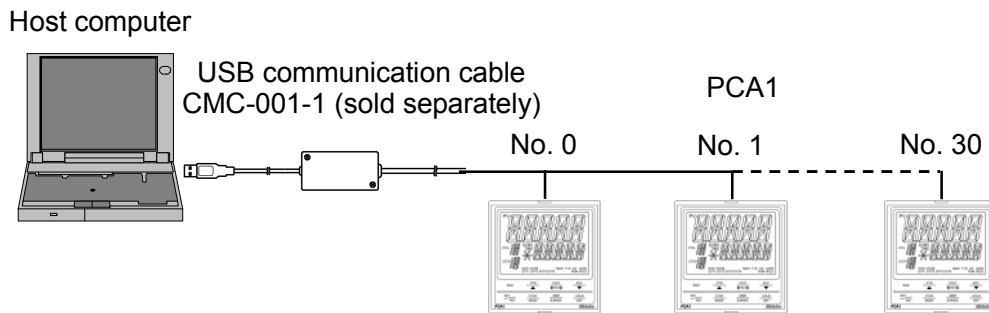

(Fig. 1.1-1)

## 1.2 When Using RS-232C Communication Line

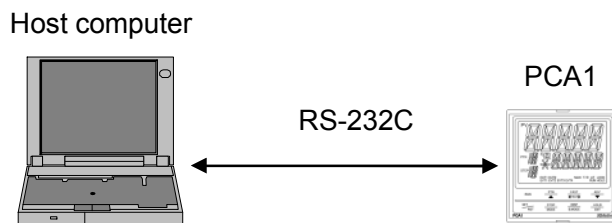

(Fig. 1.2-1)

## 1.3 When Using Communication Converter IF-400 (sold separately)

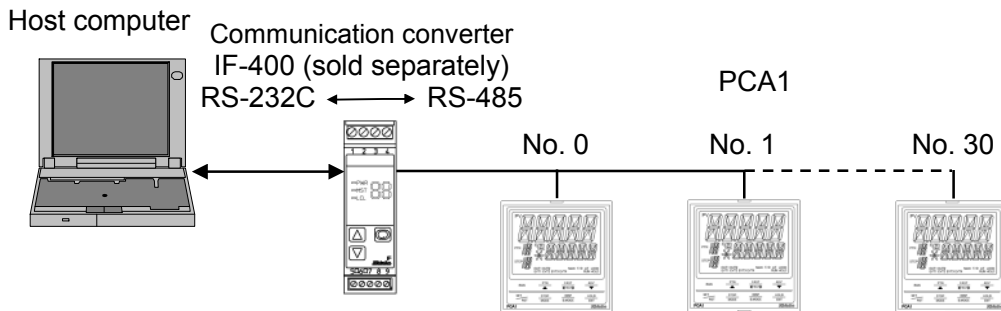

(Fig. 1.3-1)

# 2. Wiring

## 2.1 When Using USB Communication Cable CMC-001-1 (sold separately)

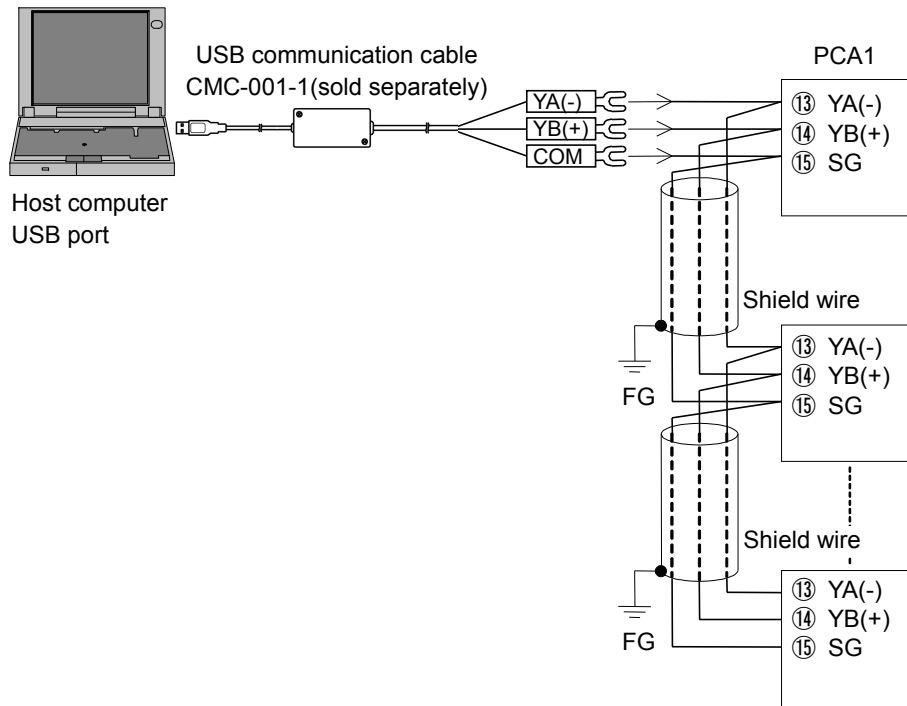

(Fig. 2.1-1)

## 2.2 When Using RS-232C Communication Line

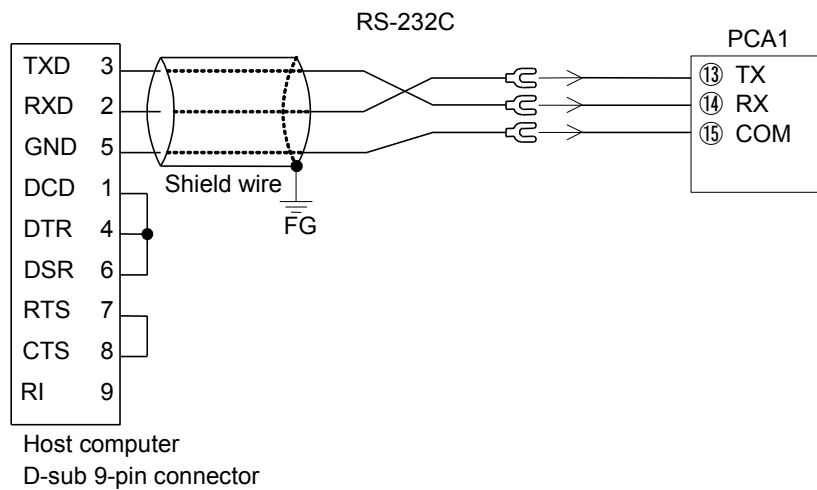

(Fig. 2.2-1)

## 2.3 When Using Communication Converter IF-400 (sold separately)

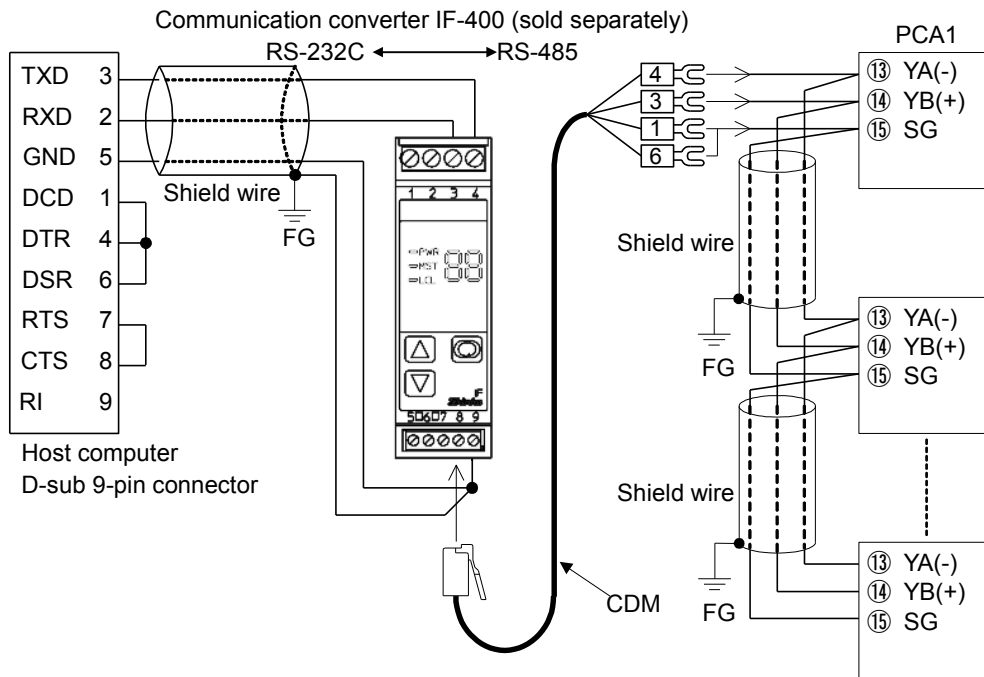

(Fig. 2.3-1)

### Shield wire

Connect only one end of the shield to the FG terminal to avoid a ground loop. If both ends of the shield wire are connected to the FG terminal, the circuit will be closed, resulting in a ground loop. This may cause noise.

Be sure to ground the FG terminal.

Recommended cable: OTSC-VB 2PX0.5SQ (made by Onamba Co., Ltd.) or equivalent (Use a twisted pair cable.)

### Terminator (Terminal resistor)

Communication converter IF-400 (sold separately) has a built-in terminator.

The terminator is mounted at the end of the wire when connecting multiple peripheral devices to a personal computer. The terminator prevents signal reflection and disturbance.

Do not connect a terminator to the communication line because each PCA1 has built-in pull-up and pull-down resistors.

# 3. Setting Communication Parameters

Set communication parameters in Communication Parameter Setting Group.

Enter the Communication Parameter Setting Group, and set communication parameters by following the procedure below.

(Abbreviation: Comm: Communication)

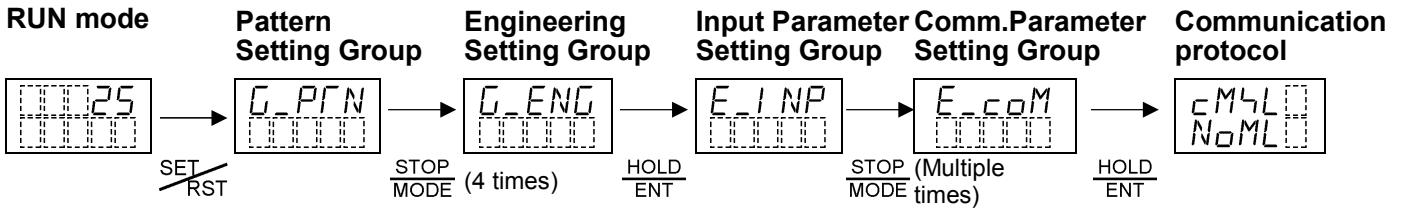

To set each item, use the  $\frac{PTN}{\Delta}$  key or  $\frac{ADV}{\nabla}$  key.

To register the set data, use the  $\frac{HOLD}{ENT}$  key.

Characters, Factory Default	Setting Item, Function, Setting Range
cM4L NoML	<b>Communication protocol</b> <ul style="list-style-type: none"> <li>Selects communication protocol.</li> <li>Selection item:</li> </ul>
	NoML   Shinko protocol
	ModA   Modbus ASCII
	ModR   Modbus RTU
	4VF   Set value (SV) digital transmission
cMNo 0000	<b>Instrument number</b> <ul style="list-style-type: none"> <li>Sets the instrument number.</li> <li>The instrument numbers should be set one by one when multiple instruments are connected in Serial communication, otherwise communication is impossible.</li> <li>Setting range: 0 to 95</li> </ul>
cM4P 0096	<b>Communication speed</b> <ul style="list-style-type: none"> <li>Selects a communication speed equal to that of the host computer.</li> <li>Selection item:</li> </ul>
	0096   9600 bps
	0192   19200 bps
	0384   38400 bps
cMFF 7EVN	<b>Data bit/Parity</b> <ul style="list-style-type: none"> <li>Selects data bit and parity.</li> <li>Selection item:</li> </ul>
	8NoN   8 bits/No parity
	7NoN   7 bits/No parity
	8EVN   8 bits/Even
	7EVN   7 bits/Even
	8odd   8 bits/Odd
	7odd   7 bits/Odd
cM4F 0001	<b>Stop bit</b> <ul style="list-style-type: none"> <li>Selects the stop bit.</li> <li>Selection item:</li> </ul>
	0001   1 bit
	0002   2 bits
cMd4 0010	<b>Response delay time</b> <ul style="list-style-type: none"> <li>Response from PCA1 can be delayed after receiving command from the host computer.</li> <li>Setting range: 0 to 1000 ms</li> </ul>

By pressing the  $\frac{SET}{RST}$  key, the unit reverts to the RUN mode. Now, settings are complete.

## 4. Communication Procedure

Communication starts with command transmission from the host computer (hereafter Master), and ends with the response of PCA1 (hereafter Slave).

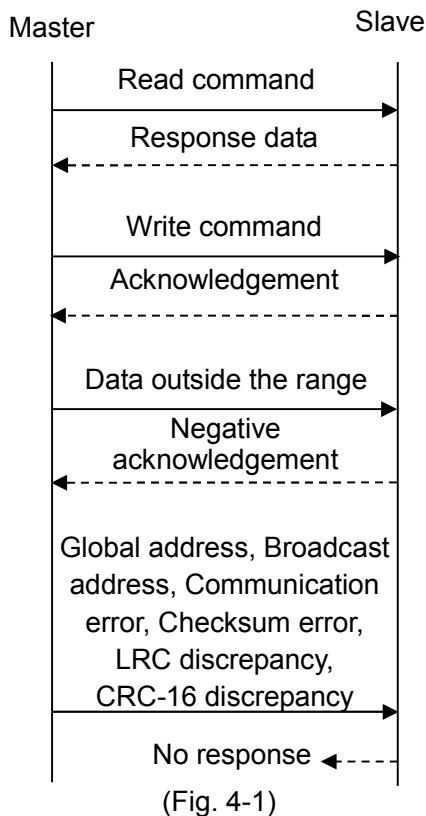

- **Response with data**

When the master sends the Read command, the slave responds with the corresponding set value or current status.

- **Acknowledgement**

When the master sends the Write command, the slave responds by sending the acknowledgement after the processing is terminated.

- **Negative acknowledgement**

When the master sends a non-existent command or value out of the setting range, the slave returns a negative acknowledgement.

- **No response**

The slave will not respond to the master in the following cases:

- Global address (Shinko protocol) is set.
- Broadcast address (Modbus protocol) is set.
- Communication error (framing error, parity error)
- Checksum error (Shinko protocol), LRC discrepancy (Modbus ASCII mode), CRC-16 discrepancy (Modbus RTU mode)

### Communication timing of the RS-485

#### Master Side (Take note while programming)

When the master starts transmission through the RS-485 communication line, the master is arranged so as to provide an idle status (mark status) transmission period of 1 or more characters before sending the command to ensure synchronization on the receiving side.

Set the program so that the master can disconnect the transmitter from the communication line within a 1 character transmission period after sending the command in preparation for reception of the response from the slave.

To avoid collision of transmissions between the master and the slave, send the next command after carefully checking that the master has received the response.

If a response to the command is not returned due to communication errors, set the Retry Processing to send the command again. (It is recommended to execute Retry twice or more.)

#### Slave Side

When the slave starts transmission through the RS-485 communication line, the slave is arranged so as to provide an idle status (mark status) transmission period of 1 ms or more (\*) before sending the response to ensure synchronization on the receiving side.

The slave is arranged so as to disconnect the transmitter from the communication line within a 1 character transmission period after sending the response.

(\*) Can be set in [Response delay time] within a range of 0 to 1000 ms. (See p.4.)

# 5. Shinko Protocol

## 5.1 Transmission Mode

Shinko protocol is composed of ASCII.

Hexadecimal (0 to 9, A to F), which is divided into high order (4-bit) and low order (4-bit) out of 8-bit binary data in command is transmitted as ASCII characters.

Data format    Start bit: 1 bit  
                     Data bit: 7 bits  
                     Parity: Even  
                     Stop bit: 1 bit

Error detection: Checksum

## 5.2 Command Configuration

All commands are composed of ASCII.

The data (values, decimal number) is represented by a hexadecimal number.

The negative numbers are represented in 2's complement.

Numerals written below the command represent number of characters.

### (1) Write command

Header (02H)	Address	Sub address (20H)	Command type (50H)	Data item	Data	Checksum	Delimiter (03H)
1	1	1	1	4	4	2	1

### (2) Read command

Header (02H)	Address	Sub address (20H)	Command type (20H)	Data item	Checksum	Delimiter (03H)
1	1	1	1	4	2	1

### (3) Response with data

Header (06H)	Address	Sub address (20H)	Command type (20H)	Data item	Data	Checksum	Delimiter (03H)
1	1	1	1	4	4	2	1

### (4) Acknowledgement

Header (06H)	Address	Checksum	Delimiter (03H)
1	1	2	1

### (5) Negative acknowledgement

Header (15H)	Address	Error code	Checksum	Delimiter (03H)
1	1	1	2	1

**Header:** Control code to represent the beginning of the command or the response.  
 ASCII is used.

Write command, Read command: STX (02H) fixed

Response with data, Acknowledgement: ACK (06H) fixed

Negative acknowledgement: NAK (15H) fixed

**Instrument number (Address):** Numbers by which the master discerns each slave.

Instrument number 0 to 94 and Global address 95.

ASCII (20H to 7FH) is used by adding 20H to instrument numbers 0 to 95 (00H to 5FH).

95 (7FH) is called Global address, which is used when the same command is sent to all the slaves connected. However, the response is not returned.

**Sub address:** 20H fixed

**Command type:** Code to discern Write command and Read command.

Command Type	Contents	Description
20H	Read	Reads data.
50H	Write	Writes data.

**Data item:** Classification of the command object.

Composed of 4-digit hexadecimal numbers, using ASCII.

Refer to '7. Communication Command Table'. (pp. 21 to 38)

**Data:** The contents of data (values) differ depending on the Write command.

Composed of 4-digit hexadecimal numbers, using ASCII.

Refer to '7. Communication Command Table'. (pp. 21 to 38)

**Checksum:** 2-character data to detect communication errors.

Refer to 5.3 Checksum Calculation on p.8.

**Delimiter:** Control code to represent the end of command.

ASCII code ETX (03H) fixed

**Error code:** Represents an error type using ASCII.

Error Code	Contents
1 (31H)	Non-existent command
2 (32H)	Not used
3 (33H)	Value outside the setting range
4 (34H)	Status unable to be written (e.g. AT is performing.)
5 (35H)	During setting mode by keypad operation

### 5.3 Checksum Calculation

Checksum is used to detect receiving errors in the command or data.

Set the program for the master side as well to calculate the checksum of the response data from the slaves so that communication errors can be checked.

The ASCII code (hexadecimal) corresponding to the characters which range from the address to that before the checksum is converted to binary notation, and the total value is calculated.

The lower one byte of the total value is converted to 2's complement, and then to hexadecimal numbers, that is, ASCII code for the checksum.

- 1's complement: Reverse each binary bit. 0 will become 1 and vice versa.
- 2's complement: Add 1 to 1's complement.

#### [Example of checksum calculation]

Writes 500°C (01F4H) to Pattern 0, Step 0, Step SV (1000H).

Address (instrument number): 1 (21H)

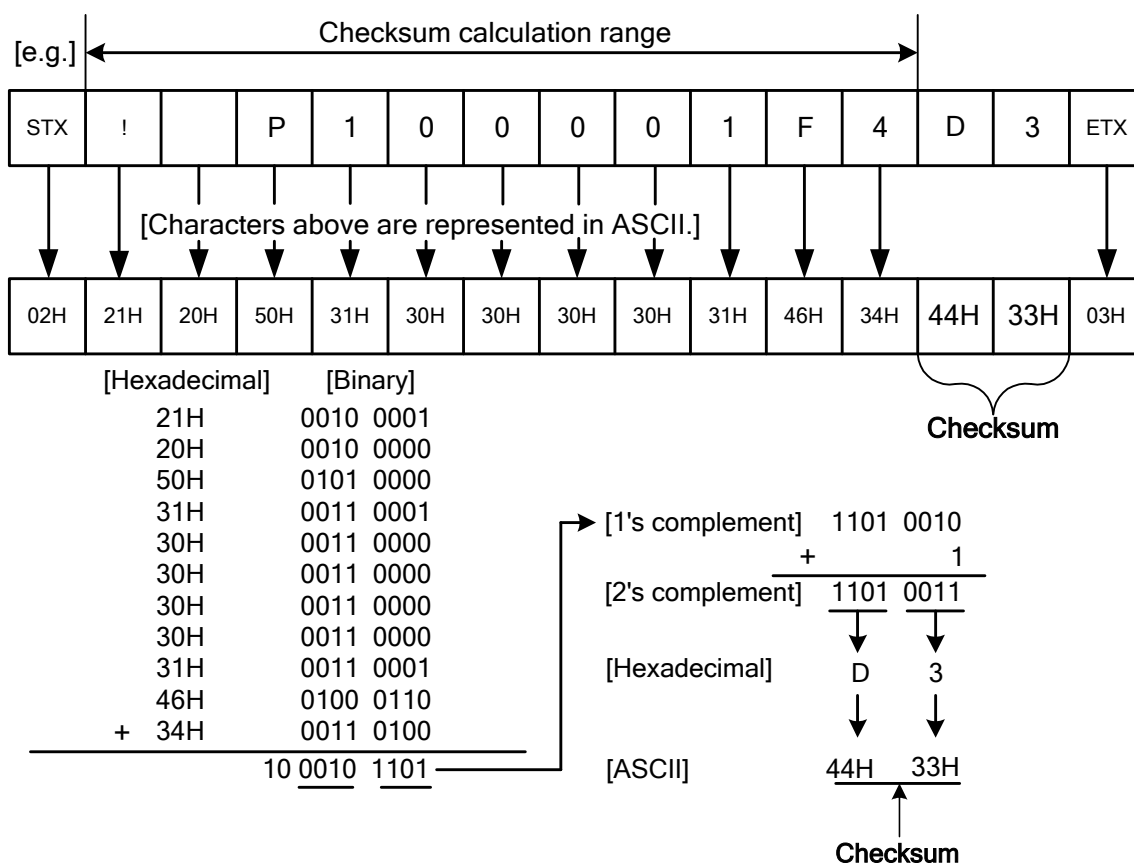

(Fig. 5.3-1)



## 5.4 Command Example

Numerals written below the command represent number of characters.

### (1) Read [Address 1, PV (0080H)]

- Read command from the master

Header (02H)	Address (21H)	Sub address (20H)	Command type (20H)	Data item [0080H] (30H 30H 38H 30H)	Checksum (44H 37H)	Delimiter (03H)
1	1	1	1	4	2	1

- A response from the slave in normal status [When PV=500°C (01F4H)]

Header (06H)	Address (21H)	Sub address (20H)	Command type (20H)	Data item [0080H] (30H 30H 38H 30H)	Data [01F4H] (30H 31H 46H 34H)	Checksum (46H 43H)	Delimiter (03H)
1	1	1	1	4	4	2	1

### (2) Write [Address 1, Pattern 0, Step 0, Step SV (1000H)]

- Write command from the master [when writing 500°C (01F4H) to Pattern 0, Step 0, Step SV (1000H)]

Header (02H)	Address (21H)	Sub address (20H)	Command type (50H)	Data item [1000H] (31H 30H 30H 30H)	Data [01F4H] (30H 31H 46H 34H)	Checksum (44H 33H)	Delimiter (03H)
1	1	1	1	4	4	2	1

- A response from the slave in normal status

Header (06H)	Address (21H)	Checksum (44H 46H)	Delimiter (03H)
1	1	2	1

### (3) Read [Address 1, Pattern 0, Step 0, Step SV (1000H)]

- Read command from the master

Header (02H)	Address (21H)	Sub address (20H)	Command type (20H)	Data item [1000H] (31H 30H 30H 30H)	Checksum (44H 45H)	Delimiter (03H)
1	1	1	1	4	2	1

- A response from the slave in normal status [When SV=500°C (01F4H)]

Header (06H)	Address (21H)	Sub address (20H)	Command type (20H)	Data item [1000H] (31H 30H 30H 30H)	Data [01F4H] (30H 31H 46H 34H)	Checksum (30H 33H)	Delimiter (03H)
1	1	1	1	4	4	2	1

# 6. Modbus Protocol

## 6.1 Transmission Mode

There are 2 transmission modes (ASCII and RTU) in Modbus protocol.

### 6.1.1 ASCII Mode

Hexadecimal (0 to 9, A to F), which is divided into high order (4-bit) and low order (4-bit) out of 8-bit binary data in command is transmitted as ASCII characters.

Data format      Start bit: 1 bit  
                         Data bit: 7 bits (8 bits) (Selectable)  
                         Parity: Even (No parity, Odd) (Selectable)  
                         Stop bit: 1 bit (2 bits) (Selectable)  
Error detection: LRC (Longitudinal Redundancy Check)

### 6.1.2 RTU Mode

8-bit binary data in command is transmitted as it is.

Data format      Start bit: 1 bit  
                         Data bit: 8 bits  
                         Parity: No parity (Even, Odd) (Selectable)  
                         Stop bit: 1 bit (2 bits) (Selectable)  
Error detection: CRC-16 (Cyclic Redundancy Check)

## 6.2 Data Communication Interval

### 6.2.1 ASCII Mode

No communication interval limit between characters

### 6.2.2 RTU Mode

1.5 character transmission times or less

(Communication speed 9600 bps, 19200 bps: 1.5 character transmission times,

Communication speed 38400 bps: 750  $\mu$ s)

To transmit continuously, an interval between characters which consist of one message, must be within 1.5 character transmission times.

If an interval lasts longer than 1.5 character transmission times, the PCA1 assumes that transmission from the master is finished, which results in a communication error, and will not return a response.

## 6.3 Message Configuration

### 6.3.1 ASCII Mode

ASCII mode message is configured to start by Header [: (colon) (3AH)], and end by Delimiter [CR (carriage return) (0DH) + LF (Line feed) (0AH)].

Header (:)	Slave address	Function code	Data	Error check LRC	Delimiter (CR)	Delimiter (LF)
---------------	------------------	------------------	------	--------------------	-------------------	-------------------

### 6.3.2 RTU Mode

RTU mode is configured to start after idle time is processed for more than 3.5 character transmissions, and end after idle time is processed for more than 3.5 character transmissions.

(Communication speed 9600 bps, 19200 bps: 3.5 character transmission times,

Communication speed 38400 bps: 1.75 ms)

3.5 idle characters	Slave address	Function code	Data	Error check CRC-16	3.5 idle characters
------------------------	------------------	------------------	------	-----------------------	------------------------

### (1) Slave Address

Slave address is an individual instrument number on the slave side, and is set within the range 0 to 95 (00H to 5FH). The master identifies slaves by the slave address of the requested message. The slave informs the master which slave is responding to the master by placing its own address in the response message.

Slave address 0 (00H, Broadcast address) can identify all the slaves connected. However, slaves do not respond.

### (2) Function Code

The function code is the command code for the slave to undertake one of the following actions.

Function Code	Contents
03(03H)	Reads a single or multiple piece(s) of data from slave(s) (Amount of data: Max. 100).
06(06H)	Writes a single piece of data to slave(s).
16(10H)	Writes multiple pieces of data to slave(s) (Amount of data: Max. 100).

The function code is used to discern whether the response is normal (acknowledgement) or if any error (negative acknowledgement) has occurred when the slave returns the response message to the master.

When acknowledgement is returned, the slave simply returns the original function code.

When negative acknowledgement is returned, the MSB of the original function code is set as 1 for the response.

For example, if the master sends request message setting 13H to the function code by mistake, slave returns 93H by setting the MSB to 1, because the former is an illegal function.

For negative acknowledgement, the exception codes below are set to the data of the response message, and returned to the master in order to inform it of what kind of error has occurred.

Exception Code	Contents
1 (01H)	Illegal function (Non-existent function)
2 (02H)	Illegal data address (Non-existent data address)
3 (03H)	Illegal data value (Value out of the setting range)
17 (11H)	Shinko protocol error code 4 (Status unable to be written. (e.g.) AT is performing.)
18 (12H)	Shinko protocol error code 5 (During setting mode by keypad operation)

### (3) Data

Data differs depending on the function code.

A request message from the master is composed of a data item, amount of data and setting data.

A response message from the slave is composed of the number of bytes, data and exception codes in negative acknowledgements, corresponding to the request message.

The effective range of data is -32768 to 32767 (8000H to 7FFFH).

Refer to Section "7. Communication Command Table" (pp.21 to 38).

### (4) Error Check

#### ASCII Mode

After calculating LRC (Longitudinal Redundancy Check) from the slave address to the end of data, the calculated 8-bit data is converted to two ASCII characters, and are appended to the end of message.

How to Calculate LRC

- ① Create a message in RTU mode.
- ② Add all the values from the slave address to the end of data. This is assumed as X.
- ③ Make a complement for X (bit reverse). This is assumed as X.
- ④ Add a value of 1 to X. This is assumed as X.
- ⑤ Set X as an LRC to the end of the message.
- ⑥ Convert the whole message to ASCII characters.

## RTU Mode

After calculating CRC-16 (Cyclic Redundancy Check) from the slave address to the end of the data, the calculated 16-bit data is appended to the end of message in sequence from low order to high order.

### How to calculate CRC-16

In the CRC-16 system, the information is divided by the polynomial series. The remainder is added to the end of the information and transmitted. The generation of a polynomial series is as follows.

(Generation of polynomial series:  $X^{16} + X^{15} + X^2 + 1$ )

- ① Initialize the CRC-16 data (assumed as X) (FFFFH).
- ② Calculate exclusive OR (XOR) with the 1st data and X. This is assumed as X.
- ③ Shift X one bit to the right. This is assumed as X.
- ④ When a carry is generated as a result of the shift, XOR is calculated by X of ③ and the fixed value (A001H). This is assumed as X. If a carry is not generated, go to step ⑤.
- ⑤ Repeat steps ③ and ④ until shifting 8 times.
- ⑥ XOR is calculated with the next data and X. This is assumed as X.
- ⑦ Repeat steps ③ to ⑤.
- ⑧ Repeat steps ③ to ⑤ up to the final data.
- ⑨ Set X as CRC-16 to the end of message in sequence from low order to high order.

## 6.4 Message Example

### 6.4.1 ASCII Mode

Numerals written below the command represent the number of characters.

#### (1) Read [Slave address 1, PV]

- A request message from the master

Header	Slave address	Function code	Data item	Amount of data	Error check LRC	Delimiter
(3AH)	(30H 31H)	(30H 33H)	(30H 30H 38H 30H)	(30H 30H 30H 31H)	(37H 42H)	(0DH 0AH)
1	2	2	4	4	2	2

- Response message from the slave in normal status [When PV=500°C]

Header	Slave address	Function code	Number of response bytes	Data	Error check LRC	Delimiter
(3AH)	(30H 31H)	(30H 33H)	(30H 32H)	(30H 31H 46H 34H)	(30H 35H)	(0DH 0AH)
1	2	2	2	4	2	2

#### (2) Read [Slave address 1, Pattern 0, Step 0, Step SV]

- A request message from the master

Header	Slave address	Function code	Data item	Amount of data	Error check LRC	Delimiter
(3AH)	(30H 31H)	(30H 33H)	(31H 30H 30H 30H)	(30H 30H 30H 31H)	(45H 42H)	(0DH 0AH)
1	2	2	4	4	2	2

- Response message from the slave in normal status [When Pattern 0, Step 0, Step SV=500°C]

Header	Slave address	Function code	Number of response bytes	Data	Error check LRC	Delimiter
(3AH)	(30H 31H)	(30H 33H)	(30H 32H)	(30H 31H 46H 34H)	(30H 35H)	(0DH 0AH)
1	2	2	2	4	2	2

- Response message from the slave in exception (error) status (When data item is incorrect)  
The function code MSB is set to 1 for the response message in exception (error) status, and 83H (ASCII: 38H 33H) is returned.

The exception code 02H (ASCII: 30H 32H) (Non-existent data address) is returned (error).

Header	Slave address	Function code	Exception code	Error check LRC	Delimiter
(3AH)	(30H 31H)	(38H 33H)	(30H 32H)	(37H 41H)	(0DH 0AH)
1	2	2	2	2	2

#### (3) Write [Slave address 1, Pattern 0, Step 0, Step SV=500°C]

- A request message from the master

Header	Slave address	Function code	Data item	Data	Error check LRC	Delimiter
(3AH)	(30H 31H)	(30H 36H)	(31H 30H 30H 30H)	(30H 31H 46H 34H)	(46H 34H)	(0DH 0AH)
1	2	2	4	4	2	2

- Response message from the slave in normal status

Header	Slave address	Function code	Data item	Data	Error check LRC	Delimiter
(3AH)	(30H 31H)	(30H 36H)	(31H 30H 30H 30H)	(30H 31H 46H 34H)	(46H 34H)	(0DH 0AH)
1	2	2	4	4	2	2

- Response message from the slave in exception (error) status (When a value out of the setting range is set)  
The function code MSB is set to 1 for the response message in exception (error) status, and 86H (ASCII: 38H 36H) is returned.

The exception code 03H (ASCII: 30H 33H) (Value out of the setting range) is returned (error).

Header	Slave address	Function code	Exception code	Error check LRC	Delimiter
(3AH)	(30H 31H)	(38H 36H)	(30H 33H)	(37H 36H)	(0DH 0AH)
1	2	2	2	2	2



Data Item		Data	Data (Converted to Hexadecimal)
1005H	Pattern 0, Step 0 Time signal 3 block number	1	0001H
1006H	Pattern 0, Step 0 Time signal 4 block number	1	0001H
1007H	Pattern 0, Step 0 Time signal 5 block number	0	0000H
1008H	Pattern 0, Step 0 Time signal 6 block number	1	0001H
1009H	Pattern 0, Step 0 Time signal 7 block number	2	0002H
100AH	Pattern 0, Step 0 Time signal 8 block number	0	0000H
100BH	Pattern 0, Step 0 Wait block number	1	0001H
100CH	Pattern 0, Step 0 Alarm block number	1	0001H
100DH	Pattern 0, Step 0 Output block number	0	0000H

**(5) Write (Slave address 1, Program pattern data) (Writing multiple pieces of data)**

- A request message from the master

Header	Slave address	Function code	Data item [1000H]
(3AH)	(30H 31H)	(31H 30H)	(31H 30H 30H 30H)
1	2	2	4

Data
[000E1C01F4001E000100000002000100010000000100020000000100010000H] (30H 30H 30H 45H 31H 43H 30H 31H 46H ···· 31H 30H 30H 30H 31H 30H 30H 30H 30H)
62

Error check LRC (39H 38H)	Delimiter (0DH 0AH)
2	2

- Response message from the slave in normal status

Header	Slave address	Function code	Data item [1000H]	Data [000EH]	Error check LRC	Delimiter
(3AH)	(30H 31H)	(31H 30H)	(31H 30H 30H 30H)	(30H 30H 30H 45H)	(44H 31H)	(0DH 0AH)
1	2	2	4	4	2	2

**(6) Read (Slave address 1, Program pattern data) (Reading multiple pieces of data)**

- A request message from the master

Header (3AH)	Slave address (30H 31H)	Function code (30H 33H)	Data item [1000H] (31H 30H 30H 30H)	Amount of data [000EH] (30H 30H 30H 45H)	Error check LRC (44H 45H)	Delimiter (0DH 0AH)
1	2	2	4	4	2	2

- Response message from the slave in normal status

Header (3AH)	Slave address (30H 31H)	Function code (30H 33H)	Number of response byte [1CH] (31H 43H)
1	2	2	2

Data
[01F4001E000100000002000100010000000100020000000100010000H]
(30H 31H 46H 34H 30H 30H 31H 45H 30H · · · · 31H 30H 30H 30H 31H 30H 30H 30H)

56

Error check LRC (43H 33H)	Delimiter (0DH 0AH)
2	2



## 6.4.2 RTU Mode

Numerals written below the command represent number of characters.

### (1) Read [Slave address 1, PV]

- A request message from the master

3.5 idle characters	Slave address (01H)	Function code (03H)	Data item (0080H)	Amount of data (0001H)	Error check CRC-16 (85E2H)	3.5 idle characters
	1	1	2	2	2	

- Response message from the slave in normal status [When PV is 500°C]

3.5 idle characters	Slave address (01H)	Function code (03H)	Number of response bytes (02H)	Data (01F4H)	Error check CRC-16 (B853H)	3.5 idle characters
	1	1	1	2	2	

### (2) Read [Slave address 1, Pattern 0, Step 0, Step SV]

- A request message from the master

3.5 idle characters	Slave address (01H)	Function code (03H)	Data item (1000H)	Amount of Data (0001H)	Error check CRC-16 (80CAH)	3.5 idle characters
	1	1	2	2	2	

- Response message from the slave in normal status [When PV is 500°C]

3.5 idle characters	Slave address (01H)	Function code (03H)	Number of response bytes (02H)	Data (01F4H)	Error check CRC-16 (B853H)	3.5 idle characters
	1	1	1	2	2	

- Response message from the slave in exception (error) status (When data item is incorrect)

The function code MSB is set to 1 for the response message in exception (error) status, and 83H is returned. The Exception code 02H (Non-existent data address) is returned (error).

3.5 idle characters	Slave address (01H)	Function code (83H)	Exception code (02H)	Error check CRC-16 (C0F1H)	3.5 idle characters
	1	1	1	2	

### (3) Write [Slave address 1, Pattern 0, Step 0, Step SV=500°C]

- A request message from the master

3.5 idle characters	Slave address (01H)	Function code (06H)	Data item (1000H)	Amount of data (01F4H)	Error check CRC-16 (8D1DH)	3.5 idle characters
	1	1	2	2	2	

- Response message from the slave in normal status

3.5 idle characters	Slave address (01H)	Function code (06H)	Data item (1000H)	Amount of data (01F4H)	Error check CRC-16 (8D1DH)	3.5 idle characters
	1	1	2	2	2	

- Response message from the slave in exception (error) status (When a value out of the setting range is set)
- The function code MSB is set to 1 for the response message in exception (error) status, and 86H is returned.

The Exception code 03H (Value out of the setting range) is returned (error).

3.5 idle characters	Slave address (01H)	Function code (86H)	Exception code (03H)	Error check CRC-16 (0261H)	3.5 idle characters
	1	1	1	2	

**(4) Write/Read of Program pattern data**

Example of program pattern setting

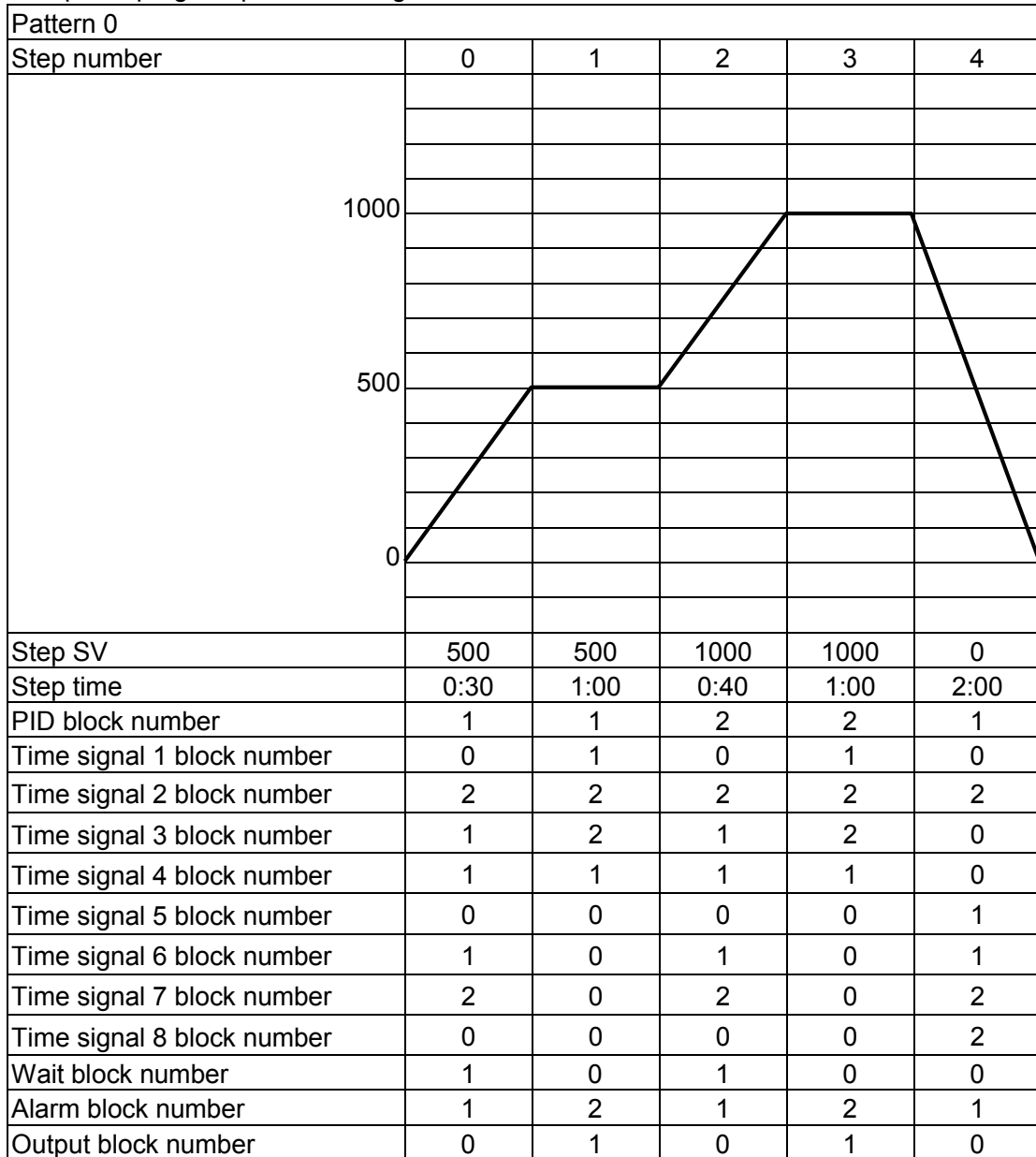

(Fig. 6.4.21)

When writing data of the above program pattern Step 0, data in the message becomes as follows:

Amount of data: 14 (000EH)

Number of bytes: 28 (1CH)

Data is converted to Hexadecimal.

Data Item		Data	Data (Converted to Hexadecimal)
1000H	Pattern 0, Step 0 Step SV	500	01F4H
1001H	Pattern 0, Step 0 Step time	0:30	001EH
1002H	Pattern 0, Step 0 PID block number	1	0001H
1003H	Pattern 0, Step 0 Time signal 1 block number	0	0000H
1004H	Pattern 0, Step 0 Time signal 2 block number	2	0002H

Data Item		Data	Data (Converted to Hexadecimal)
1005H	Pattern 0, Step 0 Time signal 3 block number	1	0001H
1006H	Pattern 0, Step 0 Time signal 4 block number	1	0001H
1007H	Pattern 0, Step 0 Time signal 5 block number	0	0000H
1008H	Pattern 0, Step 0 Time signal 6 block number	1	0001H
1009H	Pattern 0, Step 0 Time signal 7 block number	2	0002H
100AH	Pattern 0, Step 0 Time signal 8 block number	0	0000H
100BH	Pattern 0, Step 0 Wait block number	1	0001H
100CH	Pattern 0, Step 0 Alarm block number	1	0001H
100DH	Pattern 0, Step 0 Output block number	0	0000H

**(5) Write (Slave address 1, Program pattern data) (Writing multiple pieces of data)**

- A request message from the master

3.5 idle characters	Slave address (01H)	Function code (10H)	Data item (1000H)
	1	1	2

Data
(000E1C01F4001E00010000002000100010000000100020000000100010000H)
31

Error check CRC-16 (75B8H)	3.5 idle characters
2	

- Response message from the slave in normal status

3.5 idle characters	Slave address (01H)	Function code (10H)	Data item (1000H)	Data (000EH)	Error check CRC-16 (450DH)	3.5 idle characters
	2	2	4	4	2	

**(6) Read (Slave address 1, Program pattern data) (Reading multiple pieces of data)**

- A request message from the master

3.5 idle characters	Slave address (01H) 2	Function code (03H) 2	Data item (1000H) 4	Amount of data (000EH) 4	Error check CRC-16 (C0CEH) 2	3.5 idle characters
---------------------	-----------------------------	-----------------------------	---------------------------	--------------------------------	---------------------------------------	---------------------

- Response message from the slave in normal status

3.5 idle characters	Slave address (01H) 2	Function code (03H) 2	Number of response bytes (1CH) 2
---------------------	-----------------------------	-----------------------------	--

Data
(01F4001E000100000002000100010000000100020000000100010000H)
28

Error check CRC-16 (F73EH) 2	3.5 idle characters
---------------------------------------	---------------------

# 7. Communication Command Table

## 7.1 Read/Write Command

The setting range of each data is the same as that of keypad operation.

Shinko Command Type	Modbus Function Code	Data Item		Data
20H/50H	03H/06H/10H	0001H	SV in Fixed value control (*1)	Set value (Decimal point ignored)
20H/50H	03H/06H/10H	0002H	OUT1 proportional band in Fixed value control (*1)	Set value (Decimal point ignored)
20H/50H	03H/06H/10H	0003H	Integral time in Fixed value control (*1)	Set value
20H/50H	03H/06H/10H	0004H	Derivative time in Fixed value control (*1)	Set value
20H/50H	03H/06H/10H	0005H	ARW in Fixed value control (*1)	Set value
20H/50H	03H/06H/10H	0006H	OUT2 proportional band in Fixed value control (*1)	Set value (Decimal point ignored)
20H/50H	03H/06H/10H	0007H	Alarm 1 (A1) value in Fixed value control (*1)	Set value (Decimal point ignored)
20H/50H	03H/06H/10H	0008H	Alarm 2 (A2) value in Fixed value control (*1)	Set value (Decimal point ignored)
20H/50H	03H/06H/10H	0009H	Alarm 3 (A3) value in Fixed value control (*1)	Set value (Decimal point ignored)
20H/50H	03H/06H/10H	000AH	Alarm 4 (A4) value in Fixed value control (*1)	Set value (Decimal point ignored)
20H/50H	03H/06H/10H	000BH	Auto/Manual control	0000H: Automatic 0001H: Manual
20H/50H	03H/06H/10H	000CH	Manual MV (*2)	Set value (Effective for Manual control)
20H/50H	03H/06H/10H	000DH	AT mode	0000H: Normal mode 0001H: Multi mode
20H/50H	03H/06H/10H	000EH	AT Perform/Cancel (*3)	0000H: AT Cancel 0001H: AT Perform
20H/50H	03H/06H/10H	000FH	Event output EV3 allocation (*4)	0000H: No event 0001H: High limit alarm 0002H: High limit with standby 0003H: Low limit alarm 0004H: Low limit with standby 0005H: High/Low limits alarm 0006H: High/Low limits alarm with standby 0007H: High/Low limit range alarm 0008H: High/Low limit range with standby 0009H: Process high alarm 000AH: Process high alarm with standby 000BH: Process low alarm 000CH: Process low alarm with standby 000DH: Pattern end output 000EH: Loop break alarm output 000FH: Output during AT

Shinko Command Type	Modbus Function Code	Data Item		Data
20H/50H	03H/06H/10H	0010H	Event output EV4 allocation (*4)	0000H: No event 0001H: High limit alarm 0002H: High limit with standby 0003H: Low limit alarm 0004H: Low limit with standby 0005H: High/Low limits alarm 0006H: High/Low limits alarm with standby 0007H: High/Low limit range alarm 0008H: High/Low limit range with standby 0009H: Process high alarm 000AH: Process high alarm with standby 000BH: Process low alarm 000CH: Process low alarm with standby 000DH: Pattern end output 000EH: Loop break alarm output 000FH: Output during AT
20H/50H	03H/06H/10H	0011H	EV1 alarm hysteresis	Set value (Decimal point ignored)
20H/50H	03H/06H/10H	0012H	EV2 alarm hysteresis	Set value (Decimal point ignored)
20H/50H	03H/06H/10H	0013H	EV3 alarm hysteresis	Set value (Decimal point ignored)
20H/50H	03H/06H/10H	0014H	EV4 alarm hysteresis	Set value (Decimal point ignored)
20H/50H	03H/06H/10H	0015H	EV1 alarm delay time	Set value
20H/50H	03H/06H/10H	0016H	EV2 alarm delay time	Set value
20H/50H	03H/06H/10H	0017H	EV3 alarm delay time	Set value
20H/50H	03H/06H/10H	0018H	EV4 alarm delay time	Set value
20H/50H	03H/06H/10H	0019H	Loop break alarm time	Set value
20H/50H	03H/06H/10H	001AH	Loop break alarm span	Set value (Decimal point ignored)
20H/50H	03H/06H/10H	001BH	OUT1 proportional cycle	Set value
20H/50H	03H/06H/10H	001CH	OUT1 high limit (*1)	Set value
20H/50H	03H/06H/10H	001DH	OUT1 low limit (*1)	Set value
20H/50H	03H/06H/10H	001EH	OUT1 ON/OFF hysteresis	Set value (Decimal point ignored)
20H/50H	03H/06H/10H	001FH	OUT1 rate-of-change (*1)	Set value (Decimal point ignored)
20H/50H	03H/06H/10H	0020H	OUT2 proportional cycle	Set value
20H/50H	03H/06H/10H	0021H	OUT2 cooling method	0000H: Air cooling 0001H: Oil cooling 0002H: Water cooling
20H/50H	03H/06H/10H	0022H	OUT2 high limit (*1)	Set value
20H/50H	03H/06H/10H	0023H	OUT2 low limit (*1)	Set value
20H/50H	03H/06H/10H	0024H	OUT2 ON/OFF hysteresis	Set value (Decimal point ignored)
20H/50H	03H/06H/10H	0025H	Overlap/Dead band	Set value (Decimal point ignored)
20H/50H	03H/06H/10H	0026H	Open/Closed output dead band (*1)	Set value
20H/50H	03H/06H/10H	0027H	SV high limit	Set value (Decimal point ignored)
20H/50H	03H/06H/10H	0028H	SV low limit	Set value (Decimal point ignored)
20H/50H	03H/06H/10H	0029H	Transmission output type	0000H: PV transmission 0001H: SV transmission 0002H: MV transmission
20H/50H	03H/06H/10H	002AH	Transmission output high limit	Set value (Decimal point ignored)

Shinko Command Type	Modbus Function Code	Data Item		Data
20H/50H	03H/06H/10H	002BH	Transmission output low limit	Set value (Decimal point ignored)
20H/50H	03H/06H/10H	002CH	Scaling high limit	Set value (Decimal point ignored)
20H/50H	03H/06H/10H	002DH	Scaling low limit	Set value (Decimal point ignored)
20H/50H	03H/06H/10H	002EH	Decimal point place	0000H: No decimal point 0001H: 1 digit after decimal point 0002H: 2 digits after decimal point 0003H: 3 digits after decimal point 0004H: 4 digits after decimal point
20H/50H	03H/06H/10H	002FH	Sensor correction	Set value (Decimal point ignored)
20H/50H	03H/06H/10H	0030H	PV filter time constant	Set value (Decimal point ignored)
20H/50H	03H/06H/10H	0031H	Set value lock	0000H: Unlock 0001H: Lock
20H/50H	03H/06H/10H	0032H	Step SV when program control starts	Set value (Decimal point ignored)
20H/50H	03H/06H/10H	0033H	Program control start type	0000H: PV start 0001H: PVR start 0002H: SV start
20H/50H	03H/06H/10H	0034H	Power restore action	0000H: Stops 0001H: Continues 0002H: Suspends (on hold)
20H/50H	03H/06H/10H	0035H	Step time unit	0000H: Hours:Minutes 0001H: Minutes:Seconds
20H/50H	03H/06H/10H	0036H	Step time indication	0000H: Remaining time 0001H: Step time
20H/50H	03H/06H/10H	0037H	Step SV indication	0000H: SV corresponding to step time progress 0001H: Step SV
20H/50H	03H/06H/10H	0038H	Pattern end output time	Set value
20H/50H	03H/06H/10H	0039H	Step SV Hold function when program ends	0000H: Not holding 0001H: Holding
20H/50H	03H/06H/10H	003AH	Time signal output TS1/ Status (RUN) output	0000H: Time signal output TS1 0001H: Status (RUN) output
20H/50H	03H/06H/10H	003BH	Time signal output TS2/ Status (HOLD) output	0000H: Time signal output TS2 0001H: Status (HOLD) output
20H/50H	03H/06H/10H	003CH	Time signal output TS3/ Status (WAIT) output	0000H: Time signal output TS3 0001H: Status (WAIT) output
20H/50H	03H/06H/10H	003DH	Time signal output TS4/ Status (FAST) output	0000H: Time signal output TS4 0001H: Status (FAST) output
20H/50H	03H/06H/10H	003EH	Time signal output TS5/ Status (STOP) output	0000H: Time signal output TS5 0001H: Status (STOP) output

Shinko Command Type	Modbus Function Code	Data Item		Data
20H/50H	03H/06H/10H	003FH	Pattern number for operation (*5)	0000H: Pattern 0 for operation 0001H: Pattern 1 for operation 0002H: Pattern 2 for operation 0003H: Pattern 3 for operation 0004H: Pattern 4 for operation 0005H: Pattern 5 for operation 0006H: Pattern 6 for operation 0007H: Pattern 7 for operation 0008H: Pattern 8 for operation 0009H: Pattern 9 for operation 000AH: Pattern 10 for operation 000BH: Pattern 11 for operation 000CH: Pattern 12 for operation 000DH: Pattern 13 for operation 000EH: Pattern 14 for operation 000FH: Pattern 15 for operation
20H/50H	03H/06H/10H	0040H	Pattern number for setting	0000H: Pattern 0 for setting 0001H: Pattern 1 for setting 0002H: Pattern 2 for setting 0003H: Pattern 3 for setting 0004H: Pattern 4 for setting 0005H: Pattern 5 for setting 0006H: Pattern 6 for setting 0007H: Pattern 7 for setting 0008H: Pattern 8 for setting 0009H: Pattern 9 for setting 000AH: Pattern 10 for setting 000BH: Pattern 11 for setting 000CH: Pattern 12 for setting 000DH: Pattern 13 for setting 000EH: Pattern 14 for setting 000FH: Pattern 15 for setting
50H	06H/10H	0041H	Control mode (*1)	0000H: Fixed value control 0001H: Program control
50H	06H/10H	0042H	Program control Run (Cancels HOLD) /Stop	0000H: Program control Stop 0001H: Program control Run (Cancels HOLD)
50H	06H/10H	0043H	Program control HOLD (*6)	0001H: HOLD
50H	06H/10H	0044H	Program control ADVANCE (*6)	0001H: ADVANCE
50H	06H/10H	0045H	Program control PREVIOUS STEP (*6)	0001H: PREVIOUS STEP
20H/50H	03H/06H/10H	0046H	Open output time (*1)	Set value
20H/50H	03H/06H/10H	0047H	Closed output time (*1)	Set value



Shinko Command Type	Modbus Function Code	Data Item		Data
20H/50H	03H/06H/10H	0048H	Input type	0000H: K -200 to 1370°C 0001H: K -200.0 to 400.0°C 0002H: J -200 to 1000°C 0003H: R 0 to 1760°C 0004H: S 0 to 1760°C 0005H: B 0 to 1820°C 0006H: E -200 to 800°C 0007H: T -200.0 to 400.0°C 0008H: N -200 to 1300°C 0009H: PL- II 0 to 1390°C 000AH: C(W/Re5-26) 0 to 2315°C 000BH: Pt100 -200.0 to 850.0°C 000CH: JPt100 -200.0 to 500.0°C 000DH: Pt100 -200 to 850°C 000EH: JPt100 -200 to 500°C 000FH: Pt100 -100.0 to 100.0°C 0010H: Pt100 -100.0 to 500.0°C 0011H: K -328 to 2498°F 0012H: K -328.0 to 752.0°F 0013H: J -328 to 1832°F 0014H: R 32 to 3200°F 0015H: S 32 to 3200°F 0016H: B 32 to 3308°F 0017H: E -328 to 1472°F 0018H: T -328.0 to 752.0°F 0019H: N -328 to 2372°F 001AH: PL- II 32 to 2534°F 001BH: C(W/RE5-26) 32 to 4199°F 001CH: Pt100 -328.0 to 1562.0°F 001DH: JPt100 -328.0 to 932.0°F 001EH: Pt100 -328 to 1562°F 001FH: JPt100 -328 to 932°F 0020H: Pt100 -148.0 to 212.0°F 0021H: Pt100 -148.0 to 932.0°F 0022H: 4 to 20 mA -2000 to 10000 0023H: 0 to 20 mA -2000 to 10000 0024H: 0 to 10 mV -2000 to 10000 0025H: -10 to 10 mV -2000 to 10000 0026H: 0 to 50 mV -2000 to 10000 0027H: 0 to 100 mV -2000 to 10000 0028H: 0 to 1 V -2000 to 10000 0029H: 0 to 5 V -2000 to 10000 002AH: 1 to 5 V -2000 to 10000 002BH: 0 to 10 V -2000 to 10000
20H/50H	03H/06H/10H	0049H	AT bias	Set value (Decimal point ignored)
20H/50H	03H/06H/10H	004AH	Direct/Reverse action	0000H: Reverse action 0001H: Direct action

Shinko Command Type	Modbus Function Code	Data Item		Data
20H/50H	03H/06H/10H	004BH	Event output EV1 allocation (*4)	0000H: No event 0001H: High limit alarm 0002H: High limit with standby 0003H: Low limit alarm 0004H: Low limit with standby 0005H: High/Low limits alarm 0006H: High/Low limits alarm with standby 0007H: High/Low limit range alarm 0008H: High/Low limit range with standby 0009H: Process high alarm 000AH: Process high alarm with standby 000BH: Process low alarm 000CH: Process low alarm with standby 000DH: Pattern end output 000EH: Loop break alarm output 000FH: Output during AT
20H/50H	03H/06H/10H	004CH	Event output EV2 allocation (*4)	0000H: No event 0001H: High limit alarm 0002H: High limit with standby 0003H: Low limit alarm 0004H: Low limit with standby 0005H: High/Low limits alarm 0006H: High/Low limits alarm with standby 0007H: High/Low limit range alarm 0008H: High/Low limit range with standby 0009H: Process high alarm 000AH: Process high alarm with standby 000BH: Process low alarm 000CH: Process low alarm with standby 000DH: Pattern end output 000EH: Loop break alarm output 000FH: Output during AT
20H/50H	03H/06H/10H	004DH	EV1 alarm Energized/De-energized	0000H: Energized 0001H: De-energized
20H/50H	03H/06H/10H	004EH	EV2 alarm Energized/De-energized	0000H: Energized 0001H: De-energized
20H/50H	03H/06H/10H	004FH	EV3 alarm Energized/De-energized	0000H: Energized 0001H: De-energized
20H/50H	03H/06H/10H	0050H	EV4 alarm Energized/De-energized	0000H: Energized 0001H: De-energized
20H/50H	03H/06H/10H	0051H	Program start Auto/Manual	0000H: Manual start 0001H: Automatic start
20H/50H	03H/06H/10H	0052H	Overshoot suppression Enabled/Disabled	0000H: Disabled 0001H: Enabled
20H/50H	03H/06H/10H	0053H	Overshoot suppression factor	Set value (Decimal point ignored)
20H/50H	03H/06H/10H	0054H	Output status when input errors occur	0000H: Output OFF 0001H: Output ON
20H/50H	03H/06H/10H	0055H	Backlight selection	0000H: All are backlit 0001H: PV Display is backlit

Shinko Command Type	Modbus Function Code	Data Item		Data
20H/50H	03H/06H/10H	0056H	PV color	0000H: Green 0001H: Red 0002H: Orange 0003H: Alarm(EV1-EV4) ON, Green→Red 0004H: Alarm (EV1-EV4)ON: Orange→Red 0005H: PV color changes continuously 0006H: PV color changes continuously + Alarm (EV1-EV4) ON: Red
20H/50H	03H/06H/10H	0057H	PV color range	Set value (Decimal point ignored)
20H/50H	03H/06H/10H	0058H	Backlight time	Set value
20H/50H	03H/06H/10H	0059H	Response delay time	Set value
50H	06H	0070H	Key operation change flag clearing	0001H: Clear key operation change flag

## 7.2 Read Only Command

Shinko Command Type	Modbus Function Code	Data Item		Data
20H	03H	0080H	PV	Current PV
20H	03H	0081H	OUT1 MV	Current OUT1 MV
20H	03H	0082H	OUT2 MV	Current OUT2 MV
20H	03H	0083H	Current step SV	Current step SV
20H	03H	0084H	Current control step remaining time	Current step remaining time
20H	03H	0085H	Current running pattern and step (*7)	16 <sup>0</sup> digit: Running pattern 16 <sup>1</sup> digit: Running step 16 <sup>2</sup> - 16 <sup>3</sup> digits: Reserved (0)
20H	03H	0086H	Status flag 1	2 <sup>0</sup> digit: OUT1 (control output 1) 0: OFF, 1: ON 2 <sup>1</sup> digit: OUT2 (control output 2) 0: OFF, 1: ON 2 <sup>2</sup> digit: Event output EV1 0: OFF, 1: ON 2 <sup>3</sup> digit: Event output EV2 0: OFF, 1: ON 2 <sup>4</sup> digit: Event output EV3 0: OFF, 1: ON 2 <sup>5</sup> digit: Event output EV4 0: OFF, 1: ON 2 <sup>6</sup> digit: Loop break alarm 0: OFF, 1: ON 2 <sup>7</sup> digit: Overscale 0: OFF, 1: ON 2 <sup>8</sup> digit: Underscale 0: OFF, 1: ON 2 <sup>9</sup> - 2 <sup>14</sup> digits: Not used, Always 0 2 <sup>15</sup> digit: Change in key operation 0: No, 1: Yes
20H	03H	0087H	Status flag 2	2 <sup>0</sup> digit: Time signal 1 (RUN) output 0: OFF, 1: ON 2 <sup>1</sup> digit: Time signal 2 (HOLD) output 0: OFF, 1: ON 2 <sup>2</sup> digit: Time signal 3 (WAIT) output 0: OFF, 1: ON 2 <sup>3</sup> digit: Time signal 4 (FAST) output 0: OFF, 1: ON 2 <sup>4</sup> digit: Time signal 5 (STOP) output 0: OFF, 1: ON 2 <sup>5</sup> digit: Time signal 6 output 0: OFF, 1: ON 2 <sup>6</sup> digit: Time signal 7 output 0: OFF, 1: ON 2 <sup>7</sup> digit: Time signal 8 output 0: OFF, 1: ON 2 <sup>8</sup> - 2 <sup>15</sup> digits: Not used, Always 0

Shinko Command Type	Modbus Function Code	Data Item		Data
20H	03H	0088H	Current unit status	2 <sup>0</sup> digit: Control mode 1: Program control (Fixed) 2 <sup>1</sup> digit: Auto/Manual 0: Automatic 1: Manual 2 <sup>2</sup> digit: AT Perform/Cancel 0: AT Cancel 1: AT Perform 2 <sup>3</sup> digit: Program control Run/Stop 0: Program control Stop 1: Program control Run 2 <sup>4</sup> digit: Program control (HOLD) 0: OFF 1: HOLD 2 <sup>5</sup> digit: Program control (WAIT) 0: OFF 1: WAIT 2 <sup>6</sup> digit: Pattern end output 0: OFF 1: ON 2 <sup>7</sup> digit: SV Hold 0 : OFF 1 : SV Hold 2 <sup>8</sup> - 2 <sup>15</sup> digits: Not used, Always 0
20H	03H	0089H	Running pattern selected by Event input	Running pattern

### Read/Write of Multiple Pieces of Data

- For non-existent data address, if multiple pieces of data are read, acknowledgement will be returned (but data is 0).  
If multiple pieces of data are written, acknowledgement will be returned, and data will be discarded.
- For the value out of the setting range, if multiple pieces of data are written, acknowledgement will be returned, and data will be discarded.

### About Command

- (\*1) When these setting items are read, acknowledgement will be returned (but data is 0).  
When these setting items are written, acknowledgement will be returned, and data will be discarded.
- (\*2) If Write is executed in Automatic control, Error code 4 (Shinko protocol) or Exception code 17 (11H, Modbus protocol) will be returned.
- (\*3) If Write is executed in Program control standby or in Manual control, Error code 4 (Shinko protocol) or Exception code 17 (11H, Modbus protocol) will be returned.
- (\*4) Even if any alarm type is changed in [Event output EV1 – EV4 allocations], EV1– EV4 alarm values will not return to default value.
- (\*5) Effective when pattern 0 is selected externally in Program control standby.
- (\*6) If Write is executed in Program control standby, Error code 4 (Shinko protocol) or Exception code 17 (11H, Modbus protocol) will be returned.
- (\*7) When program control is stopped, the pattern number at the time of program control stop will be returned. For the step number, 0 (zero) will be returned.

## 7.3 Command for Program Control

### 7.3.1 Pattern Setting Item

Shinko Command Type	Modbus Function Code	Data Item		Data
20H/50H	03H/06H/10H	1000H	Pattern 0, Step 0 Step SV	Set value (Decimal point ignored)
20H/50H	03H/06H/10H	1001H	Pattern 0, Step 0 Step time	Set value
20H/50H	03H/06H/10H	1002H	Pattern 0, Step 0 PID block number	0000H: Block 0 0001H: Block 1 0002H: Block 2 0003H: Block 3 0004H: Block 4 0005H: Block 5 0006H: Block 6 0007H: Block 7 0008H: Block 8 0009H: Block 9
20H/50H	03H/06H/10H	1003H	Pattern 0, Step 0 Time signal 1 block number	0000H: Block 0 0001H: Block 1 0002H: Block 2 0003H: Block 3 0004H: Block 4 0005H: Block 5 0006H: Block 6 0007H: Block 7 0008H: Block 8 0009H: Block 9 000AH: Block 10 000BH: Block 11 000CH: Block 12 000DH: Block 13 000EH: Block 14 000FH: Block 15
20H/50H	03H/06H/10H	1004H	Pattern 0, Step 0 Time signal 2 block number	Same as Pattern 0, Step 0 Time signal 1 block number
20H/50H	03H/06H/10H	1005H	Pattern 0, Step 0 Time signal 3 block number	Same as Pattern 0, Step 0 Time signal 1 block number
20H/50H	03H/06H/10H	1006H	Pattern 0, Step 0 Time signal 4 block number	Same as Pattern 0, Step 0 Time signal 1 block number
20H/50H	03H/06H/10H	1007H	Pattern 0, Step 0 Time signal 5 block number	Same as Pattern 0, Step 0 Time signal 1 block number
20H/50H	03H/06H/10H	1008H	Pattern 0, Step 0 Time signal 6 block number	Same as Pattern 0, Step 0 Time signal 1 block number
20H/50H	03H/06H/10H	1009H	Pattern 0, Step 0 Time signal 7 block number	Same as Pattern 0, Step 0 Time signal 1 block number
20H/50H	03H/06H/10H	100AH	Pattern 0, Step 0 Time signal 8 block number	Same as Pattern 0, Step 0 Time signal 1 block number
20H/50H	03H/06H/10H	100BH	Pattern 0, Step 0 Wait block number	0000H: Block 0 0001H: Block 1 0002H: Block 2 0003H: Block 3 0004H: Block 4 0005H: Block 5 0006H: Block 6 0007H: Block 7 0008H: Block 8 0009H: Block 9

Shinko Command Type	Modbus Function Code	Data Item		Data
20H/50H	03H/06H/10H	100CH	Pattern 0, Step 0 Alarm block number	0000H: Block 0 0001H: Block 1 0002H: Block 2 0003H: Block 3 0004H: Block 4 0005H: Block 5 0006H: Block 6 0007H: Block 7 0008H: Block 8 0009H: Block 9
20H/50H	03H/06H/10H	100DH	Pattern 0, Step 0 Output block number	0000H: Block 0 0001H: Block 1 0002H: Block 2 0003H: Block 3 0004H: Block 4 0005H: Block 5 0006H: Block 6 0007H: Block 7 0008H: Block 8 0009H: Block 9
20H/50H	03H/06H/10H	1010H	Pattern 0, Step 1 Step SV	Set value (Decimal point ignored)
• • •	• • •	• • •	• • •	• • •
20H/50H	03H/06H/10H	1FFDH	Pattern 15, Step 15 Output block number	0000H: Block 0 0001H: Block 1 0002H: Block 2 0003H: Block 3 0004H: Block 4 0005H: Block 5 0006H: Block 6 0007H: Block 7 0008H: Block 8 0009H: Block 9

**Data Item**

16<sup>3</sup> digit: Pattern item (1 fixed)

16<sup>2</sup> digit: Pattern number (0 to F)

16<sup>1</sup> digit: Step number (0 to F)

16<sup>0</sup> digit: Data item identification number (0 to D)

**Data**

Calculate the step time using the smaller time unit in [Step time unit], then convert it to hexadecimal numbers.

Setting range: 00:00 to 99:59 [0 to 5999 (0000H to 176FH)]

(e.g.) • 1 hour 30 minutes → 90 minutes → 005AH

• 15 minutes 30 seconds → 930 seconds → 03A2H

— — — — (FFFFH): The step time is held, and Fixed value control is performed until step SV.



### 7.3.2 PID Block Item

Shinko Command Type	Modbus Function Code	Data Item		Data
20H/50H	03H/06H/10H	2000H	PID block 0 OUT1 proportional band	Set value (Decimal point ignored)
20H/50H	03H/06H/10H	2001H	PID block 0 Integral time	Set value
20H/50H	03H/06H/10H	2002H	PID block 0 Derivative time	Set value
20H/50H	03H/06H/10H	2003H	PID block 0 ARW	Set value
20H/50H	03H/06H/10H	2004H	PID block 0 OUT2 proportional band	Set value
20H/50H	03H/06H/10H	2100H	PID block 1 OUT1 proportional band	Set value (Decimal point ignored)
• • •	• • •	• • •	• • •	• • •
20H/50H	03H/06H/10H	2904H	PID block 9 OUT2 proportional band	Set value

#### Data Item

16<sup>3</sup> digit: PID block item (2 fixed)

16<sup>2</sup> digit: PID block number (0 to 9)

16<sup>1</sup> digit: Reserved (0 fixed)

16<sup>0</sup> digit: Data item identification number (0 to 4)

### 7.3.3 Wait Block Item

Shinko Command Type	Modbus Function Code	Data Item		Data
20H/50H	03H/06H/10H	3000H	Wait block 0 Wait value	Set value (Decimal point ignored)
20H/50H	03H/06H/10H	3100H	Wait block 1 Wait value	Set value (Decimal point ignored)
• • •	• • •	• • •	• • •	• • •
20H/50H	03H/06H/10H	3900H	Wait block 9 Wait value	Set value (Decimal point ignored)

#### Data Item

16<sup>3</sup> digit: Wait block item (3 fixed)

16<sup>2</sup> digit: Wait block number (0 to 9)

16<sup>1</sup> digit: Reserved (0 fixed)

16<sup>0</sup> digit: Data item identification number (0 fixed)

### 7.3.4 Alarm Block Item

Shinko Command Type	Modbus Function Code	Data Item		Data
20H/50H	03H/06H/10H	4000H	Alarm block 0 EV1 alarm value	Set value (Decimal point ignored)
20H/50H	03H/06H/10H	4001H	Alarm block 0 EV2 alarm value	Set value (Decimal point ignored)
20H/50H	03H/06H/10H	4002H	Alarm block 0 EV3 alarm value	Set value (Decimal point ignored)
20H/50H	03H/06H/10H	4003H	Alarm block 0 EV4 alarm value	Set value (Decimal point ignored)
20H/50H	03H/06H/10H	4100H	Alarm block 1 EV1 alarm value	Set value (Decimal point ignored)
• • •	• • •	• • •	• • •	• • •
20H/50H	03H/06H/10H	4903H	Alarm block 9 EV4 alarm value	Set value (Decimal point ignored)

#### Data Item

16<sup>3</sup> digit: Alarm block item (4 fixed)

16<sup>2</sup> digit: Alarm block number (0 to 9)

16<sup>1</sup> digit: Reserved (0 fixed)

16<sup>0</sup> digit: Data item identification number (0 to 3)

### 7.3.5 Output Block Item

Shinko Command Type	Modbus Function Code	Data Item		Data
20H/50H	03H/06H/10H	5000H	Output block 0 OUT1 high limit	Set value
20H/50H	03H/06H/10H	5001H	Output block 0 OUT1 low limit	Set value
20H/50H	03H/06H/10H	5002H	Output block 0 OUT2 high limit	Set value
20H/50H	03H/06H/10H	5003H	Output block 0 OUT2 low limit	Set value
20H/50H	03H/06H/10H	5004H	Output block 0 OUT1 rate-of-change	Set value (Decimal point ignored)
20H/50H	03H/06H/10H	5100H	Output block 1 OUT1 high limit	Set value
• • •	• • •	• • •	• • •	• • •
20H/50H	03H/06H/10H	5904H	Output block 9 OUT1 rate-of-change	Set value (Decimal point ignored)

#### Data Item

16<sup>3</sup> digit: Output block item (5 fixed)

16<sup>2</sup> digit: Output block number (0 to 9)

16<sup>1</sup> digit: Reserved (0 fixed)

16<sup>0</sup> digit: Data item identification number (0 to 4)

### 7.3.6 Time Signal Block Item

Shinko Command Type	Modbus Function Code	Data Item		Data
20H/50H	03H/06H/10H	6000H	Time signal block 0 Time signal output OFF time	Set value
20H/50H	03H/06H/10H	6001H	Time signal block 0 Time signal output ON time	Set value
20H/50H	03H/06H/10H	6100H	Time signal block 1 Time signal output OFF time	Set value
• • •	• • •	• • •	• • •	• • •
20H/50H	03H/06H/10H	6F01H	Time signal block 15 Time signal output ON time	Set value

#### Data Item

16<sup>3</sup> digit: Time signal block item (6 fixed)

16<sup>2</sup> digit: Time signal block number (0 to F)

16<sup>1</sup> digit: Reserved (0 fixed)

16<sup>0</sup> digit: Data item identification number (0 to 1)

#### Data

Calculate the step time using the smaller time unit in [Step time unit], then convert it to hexadecimal numbers.

(e.g.) • 1 hour 30 minutes → 90 minutes → 005AH

• 15 minutes 30 seconds → 930 seconds → 03A2H

### 7.3.7 Repetitions and Pattern Link Setting

Shinko Command Type	Modbus Function Code	Data Item		Data
20H/50H	03H/06H/10H	7000H	Pattern 0 Number of repetitions	Set value
20H/50H	03H/06H/10H	7001H	Pattern 0 and Pattern 1 Pattern link	0000H: Pattern link Disabled 0001H: Pattern link Enabled
20H/50H	03H/06H/10H	7100H	Pattern 1 Number of repetitions	Set value
• • •	• • •	• • •	• • •	• • •
20H/50H	03H/06H/10H	7F01H	Pattern 15 and Pattern 0 Pattern link	0000H: Pattern link Disabled 0001H: Pattern link Enabled

#### Data Item

16<sup>3</sup> digit: Repetitions and Pattern link setting item (7 fixed)

16<sup>2</sup> digit: Pattern number (0 to F)

16<sup>1</sup> digit: Reserved (0 fixed)

16<sup>0</sup> digit: Data item identification number (0 to 1)

## 7.4 Data

### 7.4.1 Notes about Write/Read Command

- The data (set value, decimal) is converted to a hexadecimal number. Negative numbers are represented in 2's complement.
- When connecting multiple slaves, the address (instrument number) must not be duplicated.
- Do not use undefined Data items. If they are used, negative acknowledgement will be returned or a random value will be written or read, resulting in malfunction.
- Modbus protocol uses Holding Register addresses. The Holding Register addresses are created as follows. A Shinko command data item is converted to decimal number, and the offset of 40001 is added. The result is the Holding Register address.  
Using Pattern 0, Step 0 and Step SV (1000H) as an example: Data item in the sending message is 1000H, however, Modbus protocol Holding Register address is 41001 (1000 + 40001).

### 7.4.2 Write Command

- Setting range of each item is the same as that of keypad operation.
- When data (set value) has a decimal point, a whole number (hexadecimal) without a decimal point is used.
- Writings via software communication are possible while in Set value lock status.
- Even if options are not ordered, writing via software communication will be possible. However, their command contents will not function.
- The Instrument Numbers and Communication Speed of the slave cannot be written by software communication. They can only be set via the keypad.
- When Write is executed using the Global address [95 (7FH), Shinko protocol] command or Broadcast address [0 (00H) Modbus protocol] command, the command is sent to all the connected slaves. However, a response is not returned.

### 7.4.3 Read Command

- When the data (set value) has a decimal point, a whole number (hexadecimal) without a decimal point is used for a response.

## **7.5 Negative Acknowledgement**

### **7.5.1 Error code 1 (31H, Shinko protocol)**

The slave will return Error code 1 (31H, Shinko protocol) in the following case.

- When non-existent data item is read or written.

### **7.5.2 Error code 3 (33H, Shinko protocol) or Exception code 3 (03H, Modbus protocol)**

The slave will return Error code 3 (33H, Shinko protocol) or Exception code 3 (03H, Modbus protocol) in the following case.

- When a value out of the setting range is written.

### **7.5.3 Error code 4 (34H, Shinko protocol) or Exception code 17 (11H, Modbus protocol)**

The slave will return Error code 4 (34H, Shinko protocol) or Exception code 17 (11H, Modbus protocol) in the following cases.

- While AT is performing, Write is executed.
- When 000CH (Manual MV) is written during automatic control

### **7.5.4 Error code 5 (35H, Shinko protocol) or Exception code 18 (12H, Modbus protocol)**

The slave will return Error code 5 (35H, Shinko protocol) or Exception code 18 (12H, Modbus protocol) in the following case.

- During setting mode by keypad operation



## 7.6 Notes on Programming Monitoring Software

### 7.6.1 How to Speed up the Scan Time

When monitoring multiple units of PCA1, set the program so that the requisite minimum pieces of data such as Data item 0080H (PV), Data item 0081H (OUT1 MV), Data item 0086H (Status flag 1) can be read. For other data, set the program so that they can be read only when their set value has changed. This will speed up the scan time.

### 7.6.2 How to Read the Set Value Changes Made by Front Keypad Operation

If any set value is changed by the keypad operation, the PCA1 sets the [0086H (Status flag 1) B15: Change in key operation] to 1 (Yes).

There are 2 methods of reading the set value changes made by front keypad.

#### (1) Reading method 1

- ① On the monitoring software side, check that [0086H (Status flag 1) B15: Change in key operation] has been set to 1 (Yes), then read all set values.
- ② Clear [0086H (Status flag 1) B15: Change in key operation], by writing Data item 0070H (Key operation change flag clearing) to 0001H (Clear key operation change flag).  
If 0070H (Key operation change flag clearing) is written to 0001H (Clear key operation change flag) during the setting mode of PCA1, Error code 5 (35H, Shinko protocol) or Exception Code 18 (12H, Modbus protocol) will be returned as a negative acknowledgement. And [0086H (Status flag 1) B15: Change in key operation] cannot be cleared.  
Set a program so that all set values can be read when a negative acknowledgement is returned.
- ③ Read all set values again after acknowledgement is returned.

#### (2) Reading method 2

- ① On the monitoring software side, check that [0086H (Status flag 1) B15: Change in key operation] has been set to 1 (Yes), then write the 0070H (Key operation change flag clearing) to 0001H (Clear key operation change flag).
- ② Set the program depending on the acknowledgement or negative acknowledgement as follows.  
When acknowledgement is returned;  
Consider it as settings completed, and read all set values.  
When Error code 5 (35H, Shinko protocol) or Exception code 18 (12H, Modbus protocol) is returned as a negative acknowledgement;  
Consider it as still in setting mode, and read the requisite minimum pieces of data such as 0080H (PV) 0081H (OUT1 MV), 0086H (Status flag 1), then return to Step ①.

Thus, programs which do not affect the scan time can be created using the methods described above, even if set values on the monitoring software will not be updated until settings are complete.

### 7.6.3 How to Read PID Parameters after AT Finishes

While AT is performing, the PCA1 sets [0088H (Current unit status) B2: AT Perform/Cancel] to 1 (AT Perform).

After AT is finished, PID parameters are updated.

On the monitoring software side, check that [0088H (Current unit status) B2: AT Perform/Cancel] has been set to 0 (AT Cancel), then read parameters such as P, I, D, ARW.

## 7.7 When Communicating with a PLC

To communicate with a PLC, use a Shinko PLC Interface Unit SIF-600.

No programming is needed for connection.

### PLCs corresponding to the SIF-600, its manufacturer and host link units:

PLC Manufacturer	PLC Model	Host Link Unit
Mitsubishi Electric Corp.	MELSEC Q, QnA series (*)	AJ71UC24, A1SJ71UC24-R2/R4/PRF A1SJ71C24-R2/R4/PRF, QJ71C24
	MELSEC FX series (*)	
Omron Corp.	SYSMAC CJ series	CS1W-SCU21-V1 CJ1W-SCU21, CJ1W-SCU41
Keyence Corp.	KV	KV-L20V
Yokogawa Electric Corp.	FA-M3	F3LC11-2N, F3LC11-1F, F3LC12-1F
Fuji Electric Co., Ltd.	MICREX-SX series	NP1L-RS1, NP1L-RS2, NP1L-RS3 NP1L-RS4

(\*) Models with compatible QR/QW commands (MC protocol 1C Format 4)

# 8. Set Value (SV) Digital Transmission

By selecting 'SV digital transmission' in [Communication protocol], SV of PCA1 can be sent to Shinko controllers with the C5 option.

## 8.1 Wiring

Connect YA (-) to YA (-), YB (+) to YB (+), SG to SG terminal respectively of PCA1 and controllers with the communication function.

Up to 31 units of controller can be connected.

The following shows a connection example of PCA1 and controllers with the communication function.

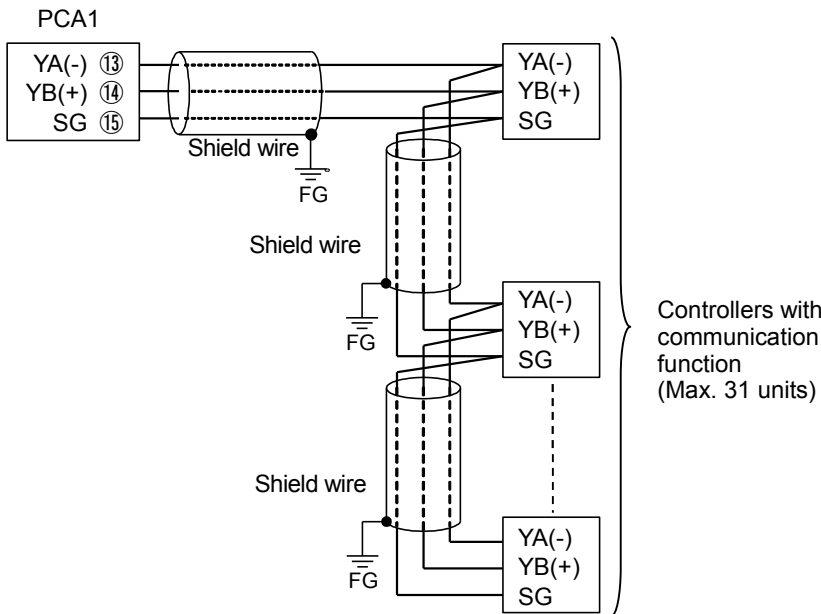

(Fig. 8.1-1)

## 8.2 Setting Method

### (1) Setting the Controller with Communication Function

- Shinko protocol has been selected in [Communication protocol].
- Communication speed of the controllers is equal to that of PCA1 (9600, 19200 or 38400 bps).

### (2) Setting the PCA1

Check the following in the Engineering setting group.

Refer to Section '3. Setting Communication Parameters' (p.4).

- 'Set value (SV) digital transmission' has been selected in [Communication protocol].
- Communication speed is set to 9600, 19200 or 38400 bps.

### (3) Starting SV digital transmission

Enter the program set values on PCA1, and press the RUN Key to perform program.

Step SV of PCA1 will be sent to the controllers.

During program control standby, 0 (zero) will be sent to the controllers.

## 9. Specifications

Cable length	RS-232C: 10 m (Max.) RS-485: 1.2 km (Max.), Cable resistance: Within 50 $\Omega$ (Terminators are not necessary, but if used, use 120 $\Omega$ or more on both sides.)			
Communication line	EIA RS-232C EIA RS-485			
Communication method	Half-duplex communication			
Communication speed	9600, 19200, 38400 bps (Selectable by keypad)			
Synchronization method	Start-stop synchronization			
Code form	ASCII, binary			
Data bit/Parity	Data bit: 7, 8 Parity: Even, Odd, No parity (Selectable by keypad)			
Stop bit	1, 2 (Selectable by keypad)			
Communication protocol	Shinko protocol, Modbus ASCII, Modbus RTU (Selectable by keypad)			
Data format				
	<b>Communication Protocol</b>	<b>Shinko Protocol</b>	<b>Modbus ASCII</b>	<b>Modbus RTU</b>
	Start bit	1	1	1
	Data bit	7	7 (8) Selectable	8
	Parity	Even	Even (No parity, Odd) Selectable	No parity (Even, Odd) Selectable
	Stop bit	1	1 (2) Selectable	1 (2) Selectable
Number of connectable units	Max 31 units to 1 host computer			
Error correction	Command request repeat system			
Error detection	Parity, checksum (Shinko protocol), LRC (Modbus ASCII), CRC-16 (Modbus RTU)			
Set value (SV) digital transmission	Sends SV to Shinko controllers with the communication function, using the C5 option (SV digital transmission).			

# 10. Troubleshooting

Check that power is being supplied to the master and slave that customers use. If communication failure still occurs, check the following.

Problem	Possible Cause	Solution
Communication failure	Communication cable is not securely connected, or is disconnected/defective.	Check the communication cable and connector.
	Incorrect wiring of the communication cable and/or connector	Check the communication cable and connector. Refer to Section '2. Wiring' (pp. 2, 3).
	Imperfect contact between the communication cable and the connector, or between the communication connector and instrument port	Check the communication cable and connector.
	Communication speed of the slave does not match that of the master.	Set the same communication speed on the master and the slave. Refer to Section '3. Setting Communication Parameters' (p. 4).
	The data bit, parity and stop bit of the master do not correspond to those of the slave.	Set the same data bit, parity and stop bit on the master and the slave. Refer to Section '3. Setting Communication Parameters' (p. 4).
	The instrument number (address) of the slave does not correspond to that of the command.	Check the instrument number (address) of the slave and the command. Refer to Section '3. Setting Communication Parameters' (p. 4).
	The instrument numbers (addresses) are duplicated in multiple slaves.	Check that each slave has a different instrument number (address). Refer to Section '3. Setting Communication Parameters' (p. 4).
	Make sure that the program is appropriate for the transmission timing.	Check the program. Refer to Section '4. Communication Procedure' (p.5).
Although communication is occurring, the response is negative acknowledgement.	A non-existent command code has been sent.	Check the command code.
	The Write command data exceeds the setting range of the slave.	Check the setting range of the slave.
	The PCA1 cannot be set when functions such as AT are performing.	Check the slave status.
	The PCA1 is in front keypad operation setting mode.	Return PCA1 to RUN mode.

For all other malfunctions, please contact our main office or dealers.

## SHINKO TECHNOS CO., LTD. OVERSEAS DIVISION

Head Office : 2-5-1, Senbahigashi, Minoo, Osaka, Japan

URL: <http://www.shinko-technos.co.jp>

E-mail: [overseas@shinko-technos.co.jp](mailto:overseas@shinko-technos.co.jp)

Tel : +81-72-727-6100

Fax: +81-72-727-7006