

ON/OFF SERVO Digital Indicating Controller Model: **ACD-15A, ACR-15A**

Model ON/OFF SERVO Digital Indicating Controller, ACD-15A-R/M, ACR-15A-R/M

Rated scale

Input (TC)	Scale range		Resolution	Input (RTD)	Scale range		Resolution	
K	-200 to 1370 °C	-328 to 2498 °F	1 °C (°F)	Pt100	-200.0 to 850.0 °C	-328.0 to 1562.0 °F	0.1 °C (°F)	
	-200.0 to 400.0 °C	-328.0 to 752.0 °F	0.1 °C (°F)		-100.0 to 100.0 °C	-148.0 to 212.0 °F	0.1 °C (°F)	
J	-200 to 1000 °C	-328 to 1832 °F	1 °C (°F)		-100.0 to 500.0 °C	-148.0 to 932.0 °F	0.1 °C (°F)	
R	0 to 1760 °C	32 to 3200 °F	1 °C (°F)		-200 to 850 °C	-328 to 1562 °F	1 °C (°F)	
S	0 to 1760 °C	32 to 3200 °F	1 °C (°F)	JPt100	-200.0 to 500.0 °C	-328.0 to 932.0 °F	0.1 °C (°F)	
B	0 to 1820 °C	32 to 3308 °F	1 °C (°F)		-200 to 500 °C	-328 to 932 °F	1 °C (°F)	
E	-200 to 800 °C	-328 to 1472 °F	1 °C (°F)	Input (DC)	Scale range		Resolution	
T	-200.0 to 400.0 °C	-328.0 to 752.0 °F	0.1 °C (°F)		4 to 20mA	-2000 to 10000 *1		1
N	-200 to 1300 °C	-328 to 2372 °F	1 °C (°F)		0 to 20mA			
PL-II	0 to 1390 °C	32 to 2534 °F	1 °C (°F)		0 to 10mV			
C(W/Re5-26)	0 to 2315 °C	32 to 4199 °F	1 °C (°F)		-10 to 10mV			
					0 to 50mV			
					0 to 100mV			
					0 to 1V			
					0 to 5V			
					1 to 5V			
				0 to 10V				

*1: Decimal point place change and scaling are possible.

General structure

Case, Material/Color : Flame-resistant resin, Black
 Panel : Membrane sheet
 Dust-proof/Drip-proof : IP66 for front face
 Indicating structure :
 ACD-15A

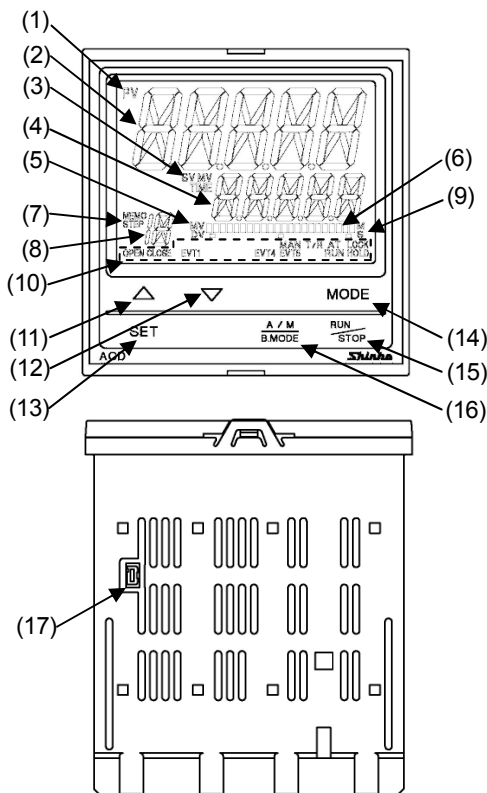

ACR-15A

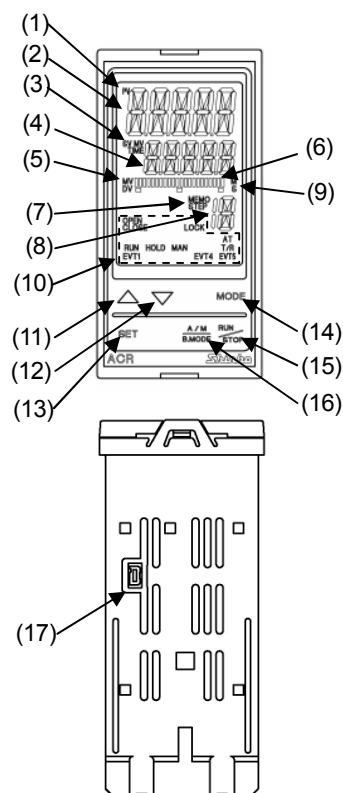

Displays

- (1) PV indicator**
Lights when PV is indicated in the PV/SV display mode.
- (2) PV display**
Indicates the PV or setting characters in the setting mode.
- (3) SV/MV/TIME indicator**
SV : Lights when SV is indicated in the PV/SV display mode.
MV : Lights when MV is indicated in the PV/SV display mode.
TIME : Lights when remaining step time (program control) is indicated in the PV/SV display mode.
- (4) SV/MV/TIME display**
Indicates the SV, MV, remaining step time (program control) or set values in each setting mode.

(5) MV/DV indicator

MV: Lights when MV (manipulated variable) is indicated on the bar graph.

DV: Lights when DV (deviation) is indicated on the bar graph.

(6) MV/DV bar graph

MV or DV (deviation) is indicated on a bar graph.

(7) MEMO/STEP indicator

MEMO : Lights when a Set value memory number is indicated.

STEP : Lights when a step number is indicated during program control. Flashes during Wait.

(8) MEMO/STEP display

Indicates the Set value memory number or step number (program control).

(9) M/S indicator

M: Lights when step time unit "Hour:Minute" is selected in the program control.

S: Lights when step time unit "Minute:Second" is selected in the program control.

(10) Action indicators

OPEN : Lights when OPEN output is ON.

CLOSED : Lights when CLOSED output is ON.

EVT1 : Lights when EVT1 (Event 1) is ON.

EVT4 : Lights when EVT4 (Event 4) is ON.

EVT5 : Lights when EVT5 (Event 5) is ON.

MAN : Lights during manual control.

T/R : Lights during Serial communication (C5 option) [TX (sending) output].

AT : Flashes while AT (auto-tuning) or auto-reset is performing.

LOCK : Lights when Set value Lock 1, Lock 2, Lock 3 or Lock 4 is selected.

RUN : Lights while program is running.

HOLD : Flashes while program is on hold (suspended).

Key operations

(11) Δ Increase key: Increases the numeric value.

If this key is pressed for 1sec during program operation (RUN), the unit proceeds to the next step. (This is an Advance function.)

(12) ∇ Decrease key: Decreases the numeric value.

(13) SET key

Switches setting groups.

Switches step numbers in the program group.

Switches Set value memory numbers in the "SV, Event group".

Switches block numbers in the PID group.

(14) MODE key

Selects the setting mode, and registers the set value.

(15) RUN/STOP key

For Fixed value control, the PV/SV display mode or standby mode can be switched by pressing this key for 1sec.

In the standby mode, pressing this key turns all outputs OFF as when the power supply is turned off.

In the program mode, control RUNS/STOPS.

In the standby mode, pressing this key RUNS program control.

Program control STOPS by pressing this key for 1sec during program operation (RUN).

(16) A/M B.MODE key

Switches Auto/Manual control.

If this key is pressed during the setting mode, the unit reverts to the previous group or mode.

Case

(17) Console connector

By connecting to the USB communication cable (CMB-001, sold separately), the following operations can be conducted from an external computer using the Console software SWS-AC001M.

- Reading and setting of SV, PID and various set values
- Reading of PV and action status
- Function change

Terminal arrangement

ACD-15A

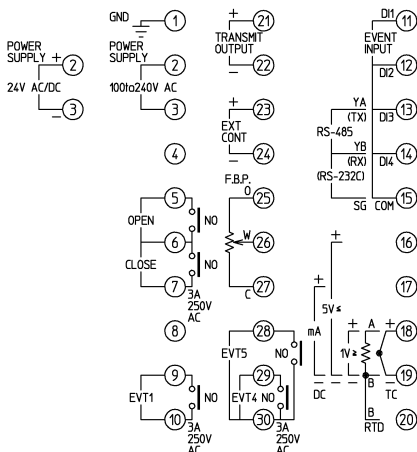

ACR-15A

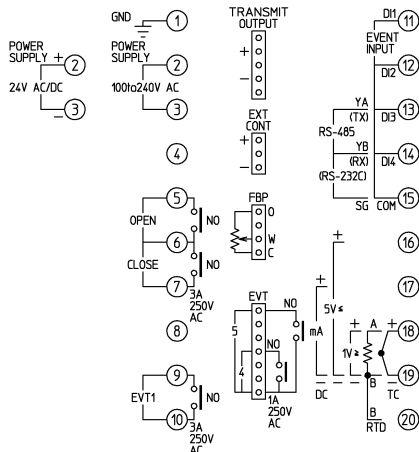

GND
POWER SUPPLY

Ground
100 to 240V AC or 24V AC/DC [For a 24V AC/DC power source, do not confuse polarity when using direct current (DC)].

OPEN
CLOSED

OPEN output
CLOSED output

EVT1	EVT1 output
EVENT INPUT	Event input (EI option)
RS-485/RS-232C	Serial communication RS-485 (C5 option) or RS-232C (C option)
TC	Thermocouple input
RTD	RTD input
DC	DC voltage, current input
	(+) side input terminal number of 0- 5V DC, 1-5V DC, 0-10V DC: 16
	(+) side input terminal number of 0-10mV DC, -10-10mV DC, 0-50mV DC, 0-100mV DC, 0-1V DC: 18
TRANSMIT OUTPUT	Transmission output (TA1, TV1 option)
EXT CONT	External setting input (EA□, EV□ option)
F.B.P	Feedback potentiometer input
EVT4	EVT4 output (A5 option)
EVT5	EVT5 output (A5 option)

Supply voltage

Model	ACD-15A-R/M 0, ACR-15A-R/M 0	ACD-15A-R/M 1, ACR-15A-R/M 1
Supply voltage	100 to 240V AC, 50/60Hz	24V AC/DC, 50/60Hz
Allowable voltage fluctuation range	85 to 264V AC	20 to 28V AC/DC

Installation specification

Dimensions	: ACD-15A: W96×H96×D98.5mm, ACR-15A: W48×H96×D98.5mm
Mounting	: Flush
Power consumption	: Approx. 13VA
Ambient temperature	: 0 to 50°C
Ambient humidity	: 35 to 85%RH (Non-condensing)
Weight	: ACD-15A: Approx. 460g, ACR-15A: Appprox. 330g

Standard functions

• EVT1 output

Output: Relay contact 1a, Control capacity, 3A 250V AC (resistive load), 1A 250V AC (inductive load $\cos\phi=0.4$)
Electrical life, 100,000 cycles

• Alarm action

High limit alarm, Low limit alarm, High/Low limits alarm, High/Low limits independent, High/Low limit range, High/Low limit range independent, Process high alarm, Process low alarm, High limit alarm with standby, Low limit alarm with standby, High/Low limits with standby, High/Low limits with standby independent

One type can be selected from 24 types (with status Energized/De-energized) and No event. (Default value: No event)

Setting accuracy : Based on the Reference accuracy and Cold junction temperature compensation accuracy

Action : ON/OFF action

Hysteresis: Thermocouple, RTD input: 0.1 to 1000.0°C (°F)

DC voltage, current input: 1 to 10000 (The placement of the decimal point follows the selection)

Output : EVT output for which alarm is selected during Event output allocation

• Loop break alarm

Setting range : Loop break alarm time; 0 to 200minutes

Loop break alarm span; 0 to 150°C (°F), 0.0 to 150.0°C (°F), DC voltage, current input: 0 to 1500 (The placement of the decimal point follows the selection)

Output : EVT output for which Loop break alarm is selected during Event output allocation

Optional specifications

• Event input (Option code: EI)

If this option and Serial communication (C, C5 option) are added together, Event input EVI3 and EVI4 cannot be used.

• Event output (Option code: A5)

Output: Relay contact 1a, Control capacity, 3A 250V AC (Resistive load), 1A 250V AC (Inductive load, $\cos\phi=0.4$), Electric life, 100,000 cycles

• Serial communication (Option code: C, C5)

If this option and Event input (EI option) are added together, Event input EVI3 and EVI4 cannot be used.

Communication interface : EIA RS-232C (C), EIA RS-485 (C5)

Communication method : Half-duplex communication start-stop synchronization

Communication speed : 9600/19200/38400bps (Selectable by keypad) (Default: 9600bps)

Data bit/Parity : 7 bits, 8bits/Even, Odd and No parity (Selectable by keypad) (Default: 7 bits/Even parity)

Stop bit : 1, 2 (Selectable by keypad) (Default: 1)

Communication protocol : Shinko protocol/Modbus ASCII/Modbus RTU, Selectable by keypad (Default: Shinko protocol)
Communication converter IF-400 is available for Modbus protocol.

Data format

Communication protocol	Shinko protocol	Modbus ASCII	Modbus RTU
Start bit	1		1
Data bit	7 or 8		8
Parity	Yes (Even, Odd) No parity		Yes (Even, Odd) No parity
Stop bit	1 or 2		1 or 2

Digital external setting (when Shinko protocol is set): Receives digital set values from Shinko programmable controllers (PC-900,

PCD-33A with SVTC option). If data from the PC-900 or PCD-33A is higher than the SV high limit or lower than SV low limit value, this instrument ignores the value, and controls at SV high limit or SV low limit value. SV adds the digital set value to SVTC bias value.

• **External setting input (option code: EA1, EA2, EV1, EV2)**

Setting signal : DC current; 4 to 20mA DC [Option code: EA1], 0 to 20mA DC [Option code: EA2]
 DC voltage; 0 to 1V DC [Option code: EV1], 1 to 5V DC [Option code: EV2]
 Allowable input : EA1, EA2; 50mA DC or less, EV1; 5V DC or less, EV2; 10V DC or less
 Input impedance : EA1, EA2; 50Ω, EV1, EV2; 100kΩ
 Input sampling period : 0.25sec

• **Transmission output (option code: TA1, TV1)**

Resolution : 1/12000
 Output : 4 to 20mA DC (load resistance, Max. 500Ω), 0 to 1V DC (load resistance, Min. 100kΩ)
 Output accuracy : Within ±0.3% of the Transmission output span

■ **Control performance**

• **Setting accuracy:** Based on the Reference accuracy and Cold junction temperature compensation accuracy

• **Control action**

PID action (with auto-tuning function), PI action, PD action (with Auto/Manual reset function), P action (with Auto/Manual reset function), ON/OFF action

Proportional band : 0 to Input span °C(°F), DC voltage, current input: 0.0 to 1000.0%
 (ON/OFF action when set to 0 or 0.0) (Default: 10°C)

Integral time : 0 to 3600sec. (OFF when set to 0) (Default: 200sec.)

Derivative time : 0 to 1800sec. (OFF when set to 0) (Default: 50sec.)

ARW : 0 to 100% (Default: 50%)

ON/OFF action hysteresis : 0.1 to 1000.0°C (°F) (Default: 1.0°C), DC voltage, current input: 1 to 10000 (The placement of the decimal point follows the selection.)

MV high limit setting : 0 to 100% (Default: 100%)

MV low limit setting : 0 to 100% (Default: 0%)

Open output time : 0.1 to 1000.0sec (Default: 30.0sec)

Closed output time : 0.1 to 1000.0sec (Default: 30.0sec)

Output time corresponds to the MV 0 to 100%.

Open/Closed output dead band : 0 to 100% of the proportional band (Default: 10%)

Open/Closed output hysteresis : 0 to 100% of the proportional band (Default: 1%)

• **Control output**

: Relay contact: 1a x 2, Control capacity 3A 250V AC (resistive load), 1A 250V AC (inductive load cosφ=0.4), Electrical life, 100,000 cycles

• **FBP resolution**

: 1/1000 (corresponds to fully open and fully closed by FBP adjustment)

■ **Insulation, Dielectric strength**

Circuit insulation configuration

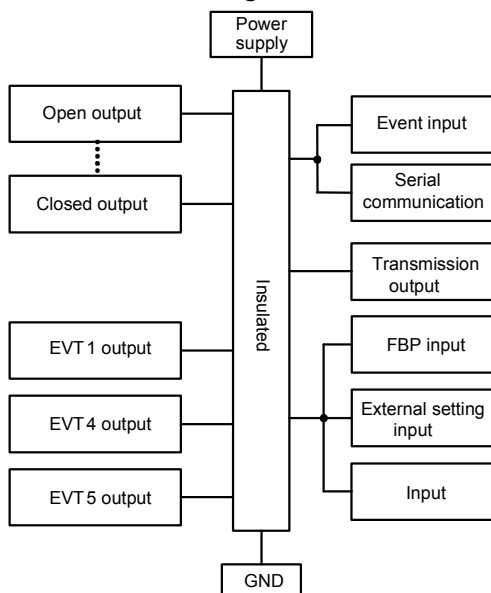

Insulation resistance: 10MΩ or more, at 500V DC

Dielectric strength:

Between power terminal and ground (GND): 1.5kV AC for 1 minute

Between input terminal and ground (GND): 1.5kV AC for 1 minute

Between input terminal and power terminal: 1.5kV AC for 1 minute

■ **Indicating performance**

Reference accuracy:

Thermocouple : Within ±0.2% of each input span ± 1digit,
 However R, S input, -50 to 200°C (-58 to 392°F): Within ±6°C (12°F)
 B input, 0 to 300°C (0 to 572°F): Accuracy is not guaranteed

K, J, E, T, N input, less than 0°C(32°F): Within ±0.4% of the input span ± 1digit

RTD : Within ±0.1% of each input span ± 1digit

DC current, voltage: Within ±0.2% of each input span ± 1digit

External setting input accuracy : Within ±0.2% of External setting input span

Cold junction temperature compensation accuracy: Within ±1°C at 0 to 50°C

Input sampling period : 0.125 seconds (0.25 seconds when EA□ or EV□ option is added)

Time accuracy : Within ±1.0% of the setting time

Attached functions

Sensor correction, Set value lock, Auto/Manual control switching, Program control function, Set value ramp function, Power failure countermeasure, Self-diagnosis, Automatic cold junction temperature compensation, Burnout, Overscale, Input abnormality, Indication range and Control range, Warm-up indication Console communication, PV color selection, Timer function, Bar graph, PID zone function

Accessories included

Mounting brackets 1 set,
Gasket (Front mounted to the unit) 1 piece,
Instruction manual 1 copy,
Communication instruction manual (C, C5 option) 1 copy

For the ACR-15A only:

Harness FBP : 1 piece
Harness EVT5 : 1 piece [When Event output (A5 option) is added]
Harness E : 1 piece [when External setting input (EA1, EA2, EV1, EV2 option) is added]
Harness VT : 1 piece [When Transmission output (TA1, TV1 option) is added]

Accessories sold separately

Terminal cover,
USB communication cable (CMB-001)

Environmental specification: Conforms to RoHS directive.

Dimensions (Scale: mm)

ACD-15A

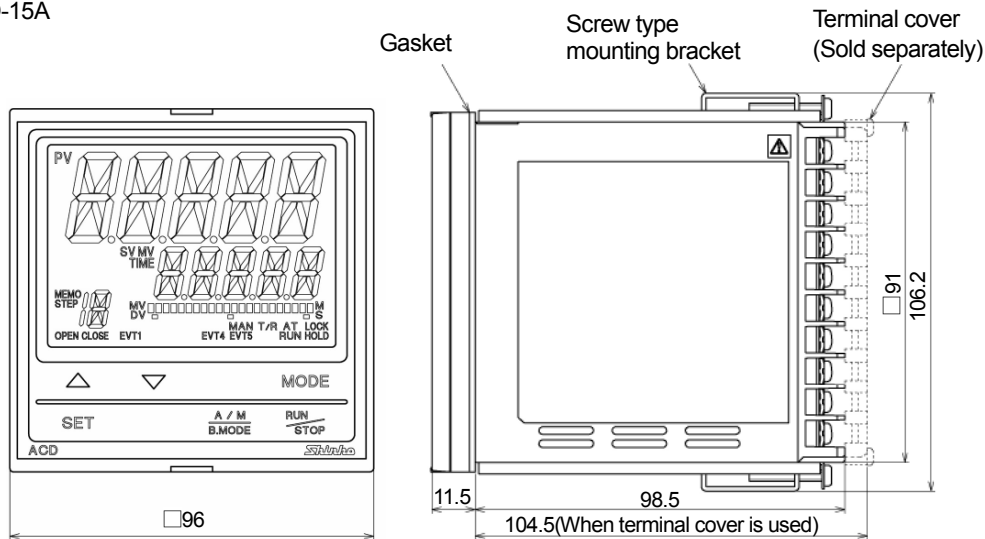

ACR-15A

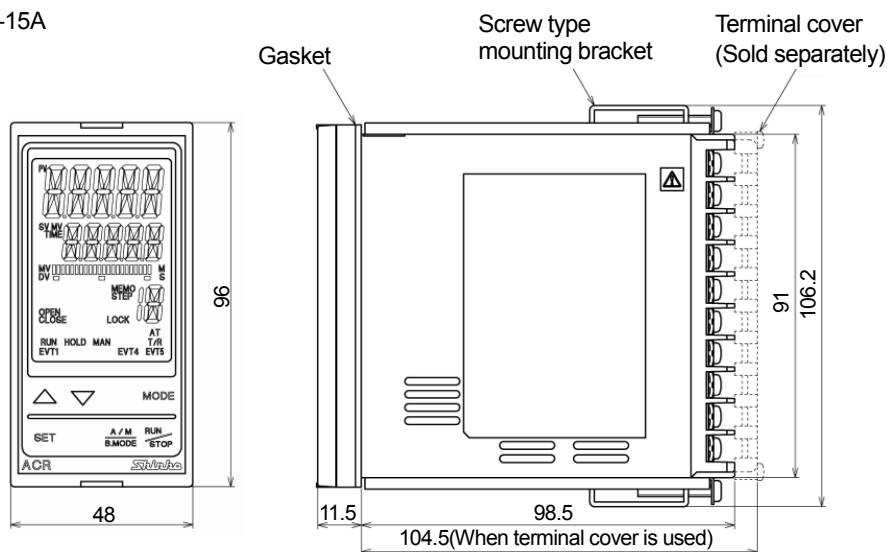

■ Panel cutout (Scale: mm)

ACD-15A

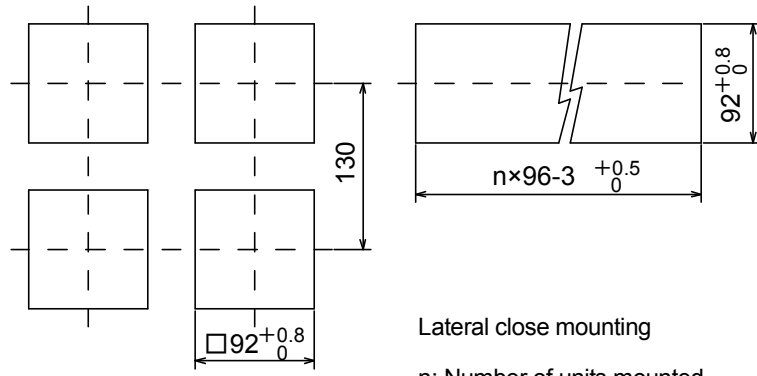

Lateral close mounting
n: Number of units mounted

ACR-15A

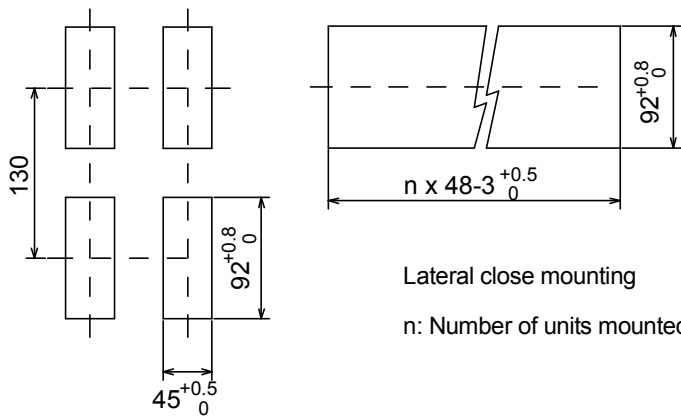

Lateral close mounting
n: Number of units mounted